

**Kanalventilatoren** mit vorwärts- und rückwärts-gekrümmten Radiallaufrädern

*Duct Fans with forward and backward curved centrifugal impellers*

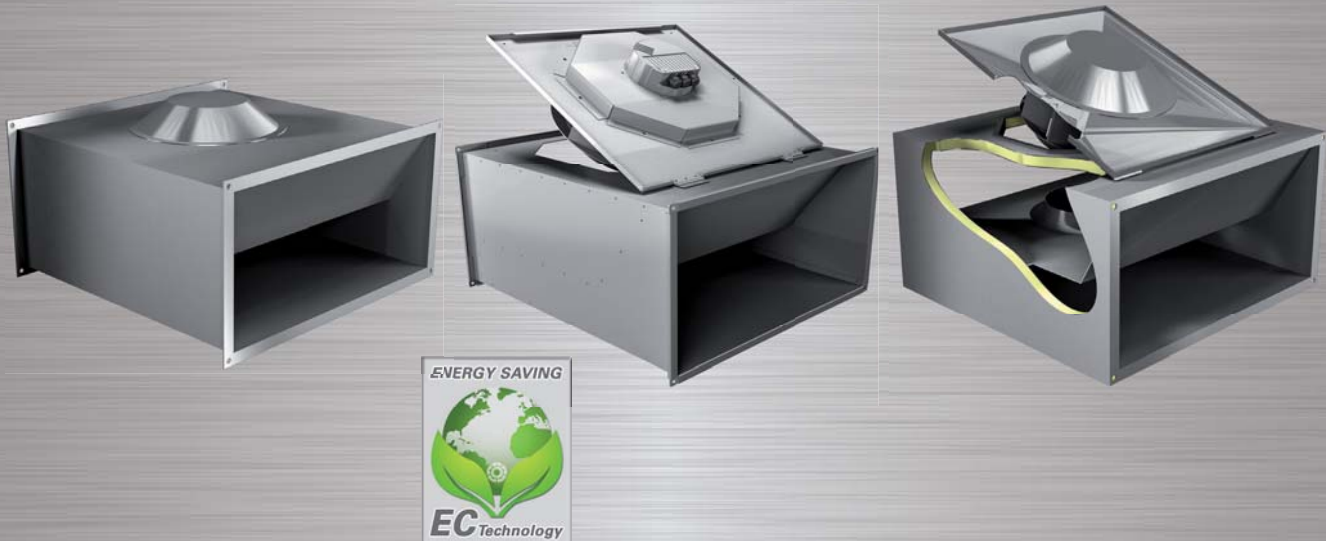

**Typenschlüssel / Type Code**

Kanalventilator / *duct fan*  
 Hochleistungs-Radiallaufrad rückwärtsgekrümmt /  
*high efficiency centrifugal impeller backward curved*  
 A = Außenläufermotor / *external rotor motor*  
 E = Einphasen-Wechselstrom / *single phase A.C.*  
 D = Drehstrom / *three phase alternating current*  
 G = EC-Motor / *EC motor*  
 Laufraddurchmesser / *impeller diameter*  
 Polzahl / *number of poles*  
 Wirkungsgradoptimiertes Laufrad /  
*efficiency optimized impeller*  
 Schallgedämmt / *sound attenuated*  
 Motortyp / *motor type* (5=112 ; 6=150)  
 Paketlänge / *stack length*

**K H A E 250 - 4.. W S .6 IF**

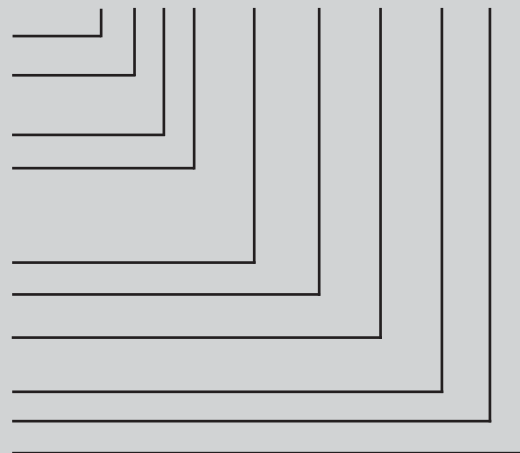

einseitig saugend / *single inlet*  
 Kanalventilator / *duct fan*  
 Aussenläufermotor / *external rotor motor*  
 E = Einphasen-Wechselstrom / *single phase A.C.*  
 D = Drehstrom / *three phase alternating current*  
 Laufraddurchmesser / *impeller diameter*  
 Polzahl / *number of poles*  
 Kleinerer Antriebsmotor / *smaller motor*

**E K A E 225 - 4 K**

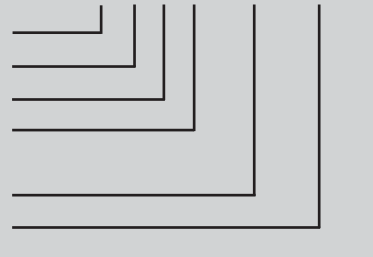

## Eigenschaften und Ausführungen

Die Rosenberg-Kanalventilatoren vereinigen die Vorteile des Axialventilators - der geraden Durchströmung und einfachen Montage - mit der hohen Druckstabilität, dem niedrigen Schallniveau und ausgezeichneten Wirkungsgrad des Radialventilators.

## Gehäuse

Die Gehäuse sind aus verzinktem Stahlblech hergestellt und als rechteckiger Kanal ausgebildet, zum direkten Einbau in Luftkanäle in jeder beliebigen Einbaulage. Saug- und Druck-seitig sind mit Normflanschen ausgestattet. Die komplette Motor-Laufradeinheit lässt sich zu Reinigungszwecken ausklappen (KHAE/D/G). Die schallgedämmte Baureihe (.WS) bietet durch platzsparende, schallabsorbierende Lochblechauskleidung an prägnanten Punkten extrem niedrige Geräuschwerte.

## Laufblätter

Die Trommellaufblätter aus verzinktem Stahlblech (bei EKAE/D) sowie die Aluminiumblechlaufblätter (ALMg3) mit rückwärtsgekrümmten Schaufeln sind direkt auf die Rotoren der Außenläufermotoren aufgebaut und zusammen mit diesen entsprechend Gütestufe G2.5 nach DIN1940 auf 2 Ebenen dynamisch ausgewuchtet.

## Elektrischer Anschluss

Die Antriebsmotoren haben ein ausgeführtes Kabel. Der elektrische Anschluss erfolgt durch einen lose beigefügten Anschlusskasten in Schutzart IP44.

## Drehrichtung

Die Drehrichtung ist auf Ansaugseite gesehen rechtsdrehend.

## Luftleistungskennlinien

Die Kennlinien für diese Typenreihen wurden in Einbauart D (ansaugseitig und druckseitig angeschlossen) aufgenommen und zeigen die Gesamtdruckerhöhung  $\Delta p_t$  als Funktion des Volumenstromes. Der dynamische Druck  $\Delta p_{d2}$  ist auf den Flanschquerschnitt am Ventilatoraustritt bezogen.

## Geräusche

In den Luftleistungskennlinien ist der A-bewertete Freiausblas-Schallleistungspegel  $L_{WA6}$  angegeben (umrandete Zahlen). Der A-bewertete Freiansaug-Schallleistungspegel  $L_{WA5}$  nach DIN 45 635, Teil 38 wird wie folgt ermittelt:

$$L_{WA5} [dB(A)] = L_{WA6} [dB(A)] - 6 \text{ dB}$$

Den A-bewerteten Schalldruckpegel  $L_{pA}$  in 1m Abstand erhält man annähernd, in dem man vom A-Schallleistungspegel 7 dB(A) abzieht. Zu beachten ist, dass Reflexionen und Raumcharakteristik, sowie Eigenfrequenzen die Größe des Schalldruckpegels unterschiedlich beeinflussen. Die relativen Oktav-Schallleistungspegel  $L_{WArel}$  bei den Oktav-Mittelfrequenzen sind aus den direkt zugeordneten Tabellen der jeweiligen Ventilatorentypen zu entnehmen.

## Features and Construction

The Rosenberg duct fans provide a distinctive advantage of axial fans, i.e. straight airflow and easy installation, high pressure stability, low noise level and high efficiency of the centrifugal fan.

## Casing

Casings are made of galvanized sheet steel, formed as a rectangular duct, for direct installation into air ducts. Mounting in any position possible. On inlet and outlet side are standard flanges. Equipped with complete swing-out motorized impellers for easy inspection cleaning and maintenance (KHAE/D/G). The sound attenuated duct fans (.WS) offer with a space saving and sound absorbing casing extremely low noise levels.

## Impellers

The forward curved impellers are made of galvanized sheet steel (EKAE/D) and the impellers with backward curved blades made of sheet aluminium (ALMg3) are mounted directly to the rotor of the external rotor motor and are balanced dynamically together with the rotor according to quality level G2.5 to DIN1940.

## Electrical connection

The motors are fitted with an outgoing cable. The electrical connection can be made via an IP44 terminal box, which is supplied loose.

## Direction of rotation

Direction of rotation is clockwise, viewed from the inlet side.

## Air performance curves

The performance curves for these fan types have been measured in mounting position D (ducted on the pressure side and on the suction side) and show the total pressure increase  $\Delta p_t$  as a function of the air flow. The dynamic pressure  $\Delta p_{d2}$  refers to the flange cross section at the outlet side of the fan.

## Noise levels

The bordered values printed in the performance curve diagrams show the „A“ weighted  $L_{WA6}$  sound power level (fan outlet). Determination of „A“ weighted  $L_{WA5}$  sound power level at fan inlet:

$$L_{WA5} [dB(A)] = L_{WA6} [dB(A)] - 6 \text{ dB}$$

The „A“ weighted sound pressure level  $L_{pA}$  at a distance of 1 metre is calculated approximately by deducting 7 dB(A) from the „A“ weighted sound power level. It is important to note that the reflection and room characteristic as well as natural frequencies influence the sound pressure levels a different way. The relative octave sound power level  $L_{WArel}$  at octave medium frequency you can find on the table on each fan type page.





- integrierte Regelung (EC-Controller)
  - Komplettsystem mit minimierten Betriebskosten durch den Einsatz von EC-Technik
  - einfache Einregelung und Anpassung an die Anlage
  - stufenlos steuerbar oder regelbar
  - schnelle Montage DIN-Normflansch
  - rückwärtsgekrümmtes Laufrad
  - kompakte, raumsparende Bauart
  - Motorschutz durch Thermokontakte
- *integrated control system (EC controller)*
  - *completed system with minimal operating costs, based on use of EC technology*
  - *simple setting and adjustment of the complete system*
  - *speed is 100% infinitely variable*
  - *easy installation (DIN standard flange)*
  - *backward curved impeller*
  - *compact and space saving design*
  - *motor protection by thermal contacts*

### Technische Daten / Technical Data:

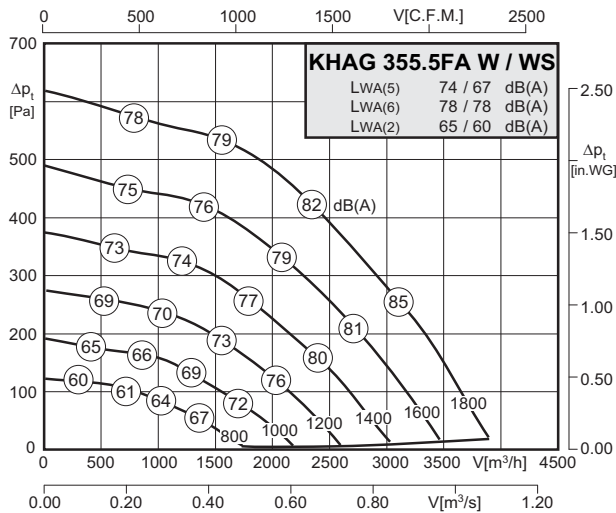

**Energieeinsparung gegenüber dem AC Typ bis zu: / Energy saving rate according to AC type up to:**  
**35%\***

\* im drehzahlgesteuerten Teillastbereich \* at speed controlled partial load range

Type: KHAG 355.5FA W/WS		Art.-No.: D15-35500 / D15-35510	
U	400V (50Hz)	Δp <sub>fa min</sub>	- Pa
P <sub>1</sub>	0.6 kW	ΔI	- %
I <sub>N</sub>	1.06 A	I <sub>A</sub> / I <sub>N</sub>	-
n	1800 min <sup>-1</sup>		IP54
C <sub>400V</sub>	- μF		01.390 a)
t <sub>R</sub>	60 °C		36 kg

### Geräusche / Sound levels:

LWA <sub>rel</sub> A-bewertet bei V=0,5*V <sub>max</sub> LWA <sub>rel</sub> A-weighted at V=0,5*V <sub>max</sub>	fM [Hz]						
	125	250	500	1K	2K	4K	8K
LWA <sub>2</sub> [dB(A)] Gehäuse / casing	-4	-5	-12	-12	-15	-21	-27
LWA <sub>5</sub> [dB(A)] Ansaugseite / inlet side	-11	-5	-9	-9	-7	-11	-20
LWA <sub>6</sub> [dB(A)] Ausblasseite / outlet side	-10	-9	-6	-5	-6	-13	-22

### Maße / Dimensions:

(alle Maße in mm / all dimensions in mm)

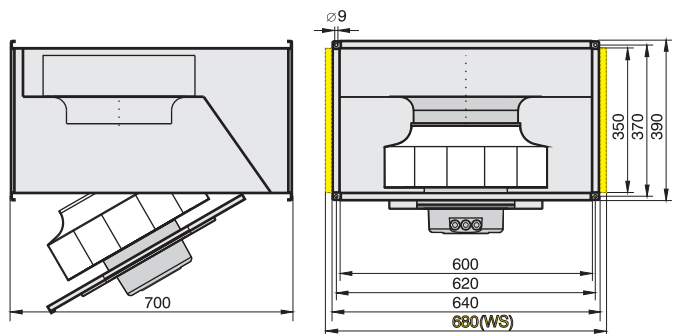

### Schaltbild / Wiring diagram:

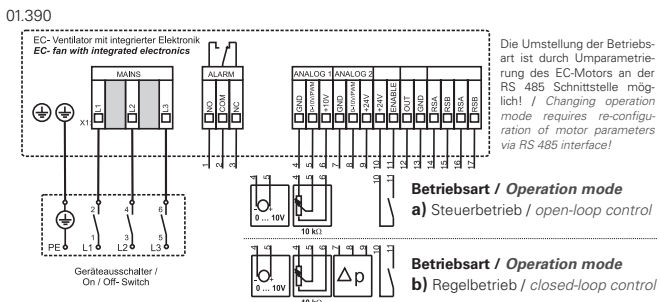

### Zubehör / Accessories:





- integrierte Regelung (EC-Controller)
  - Komplettsystem mit minimierten Betriebskosten durch den Einsatz von EC-Technik
  - einfache Einregelung und Anpassung an die Anlage
  - stufenlos steuerbar oder regelbar
  - schnelle Montage DIN-Normflansch
  - rückwärtsgekrümmtes Laufrad
  - kompakte, raumsparende Bauart
  - Motorschutz durch Thermokontakte
- *integrated control system (EC controller)*
  - *completed system with minimal operating costs, based on use of EC technology*
  - *simple setting and adjustment of the complete system*
  - *speed is 100% infinitely variable*
  - *easy installation (DIN standard flange)*
  - *backward curved impeller*
  - *compact and space saving design*
  - *motor protection by thermal contacts*

**Technische Daten / Technical Data:**

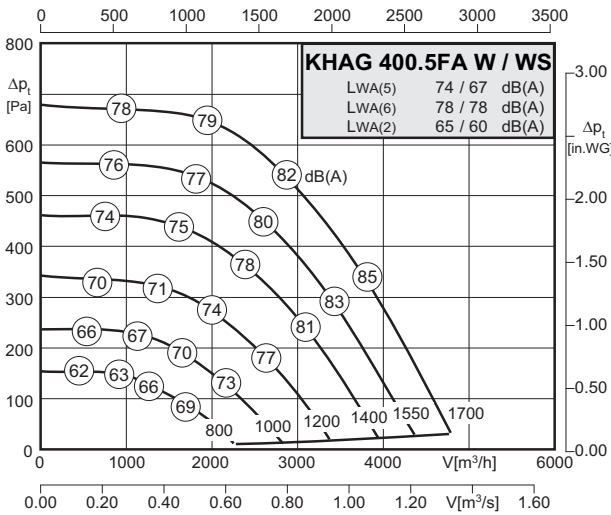

**Energieeinsparung gegenüber dem AC Typ bis zu: / Energy saving rate according to AC type up to:**  
**35%\***

\* im drehzahlgesteuerten Teillastbereich \* at speed controlled partial load range

Type: KHAG 400.5FA W/WS		Art.-No.: D15-40000 / D15-40010	
U	400V (50Hz)	Δp <sub>fa min</sub>	-- Pa
P <sub>1</sub>	0.96 kW	ΔI	-- %
I <sub>N</sub>	1.7 A	I <sub>A</sub> / I <sub>N</sub>	--
n	1700 min <sup>-1</sup>	⚠	IP54
C <sub>400V</sub>	-- μF	⚡	01.390 a)
t <sub>R</sub>	40 °C	🔥	36,5 kg

**Geräusche / Sound levels:**

LWA <sub>rel</sub> A-bewertet bei V=0,5*V <sub>max</sub> LWA <sub>rel</sub> A-weighted at V=0,5*V <sub>max</sub>		f [Hz]						
		125	250	500	1K	2K	4K	8K
LWA <sub>2</sub> [dB(A)]	Gehäuse / casing	-4	-3	-11	-13	-18	-21	-28
LWA <sub>5</sub> [dB(A)]	Ansaugseite / inlet side	-7	-5	-11	-9	-8	-12	-20
LWA <sub>6</sub> [dB(A)]	Ausblasseite / outlet side	-10	-8	-7	-6	-7	-11	-21

**Maße / Dimensions:**

(alle Maße in mm / all dimensions in mm)

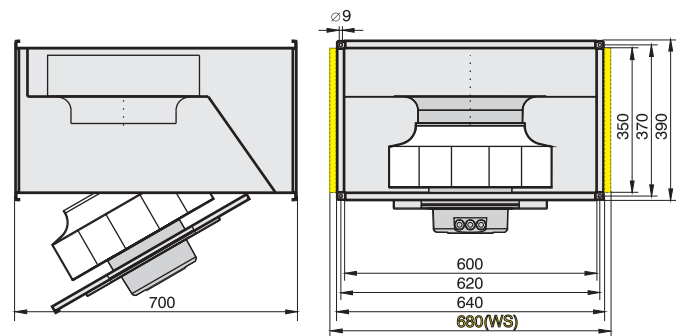

**Schaltbild / Wiring diagram:**

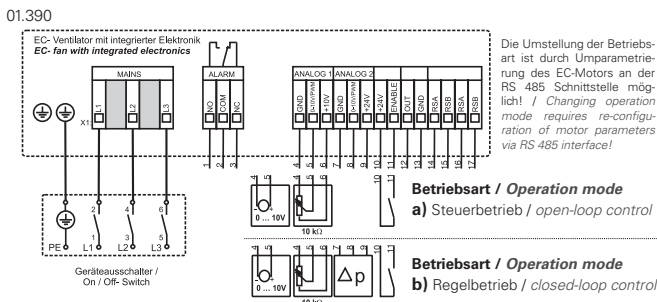

**Zubehör / Accessories:**



**GS** Seite/Page 404  
**POT 1** Seite/Page 415  
**POT 2** Seite/Page 415  
**PU** Seite/Page 415  
**KD** Seite/Page 424  
**FKV** Seite/Page 424  
**GF** Seite/Page 425  
**VK** Seite/Page 425  
**VKJ** Seite/Page 426  
**KFB** Seite/Page 426



- integrierte Regelung (EC-Controller)
  - Komplettsystem mit minimierten Betriebskosten durch den Einsatz von EC-Technik
  - einfache Einregelung und Anpassung an die Anlage
  - stufenlos steuerbar oder regelbar
  - schnelle Montage DIN-Normflansch
  - rückwärtsgekrümmtes Laufrad
  - kompakte, raumsparende Bauart
  - Motorschutz durch Thermokontakte
- *integrated control system (EC controller)*
  - *completed system with minimal operating costs, based on use of EC technology*
  - *simple setting and adjustment of the complete system*
  - *speed is 100% infinitely variable*
  - *easy installation (DIN standard flange)*
  - *backward curved impeller*
  - *compact and space saving design*
  - *motor protection by thermal contacts*

**Technische Daten / Technical Data:**

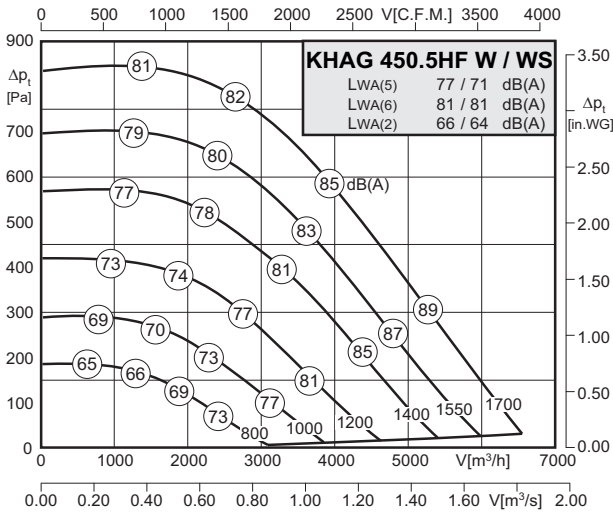

**Energieeinsparung gegenüber dem AC Typ bis zu: / Energy saving rate according to AC type up to:**  
**35%\***

\* im drehzahlgesteuerten Teillastbereich \* at speed controlled partial load range

<b>Type: KHAG 450.5HF W/WS</b>		<b>Art.-No.: D15-45000 / D15-45010</b>	
U	400V (50Hz)	$\Delta p_{fa}$ min	- Pa
P <sub>1</sub>	2.3 kW	$\Delta I$	- %
I <sub>N</sub>	2.4 A	I <sub>A</sub> / I <sub>N</sub>	-
n	1700 min <sup>-1</sup>		IP54
C <sub>400V</sub>	- µF		01.390 a)
t <sub>R</sub>	50 °C		55 kg

**Geräusche / Sound levels:**

LWA <sub>rel</sub> A-bewertet bei V=0,5*V <sub>max</sub> LWA <sub>rel</sub> A-weighted at V=0,5*V <sub>max</sub>		fM [Hz]						
		125	250	500	1K	2K	4K	8K
LWA <sub>2</sub> [dB(A)]	Gehäuse / casing	-7	-4	-8	-11	-15	-20	-27
LWA <sub>5</sub> [dB(A)]	Ansaugseite / inlet side	-14	-9	-3	-7	-8	-14	-22
LWA <sub>6</sub> [dB(A)]	Ausblasseite / outlet side	-15	-9	-7	-5	-8	-13	-23

**Maße / Dimensions:**

(alle Maße in mm / all dimensions in mm)

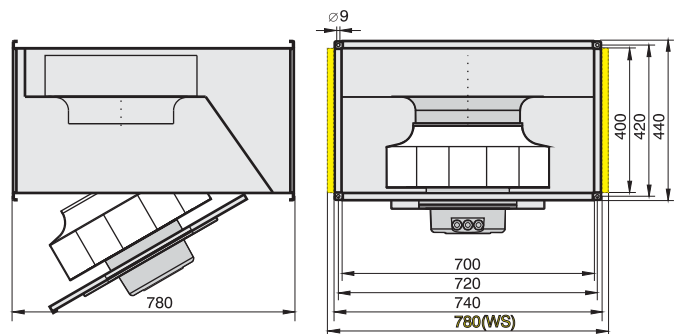

**Schaltbild / Wiring diagram:**

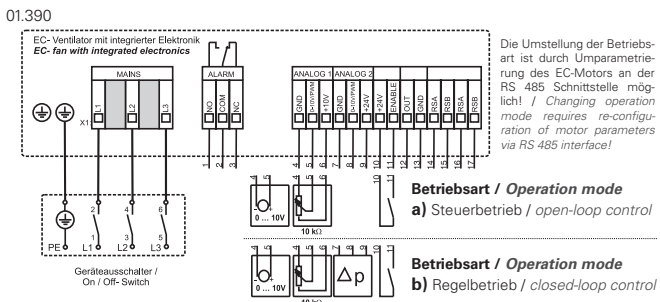

**Zubehör / Accessories:**





- integrierte Regelung (EC-Controller)
  - Komplettsystem mit minimierten Betriebskosten durch den Einsatz von EC-Technik
  - einfache Einregelung und Anpassung an die Anlage
  - stufenlos steuerbar oder regelbar
  - schnelle Montage DIN-Normflansch
  - rückwärtsgekrümmtes Laufrad
  - kompakte, raumsparende Bauart
  - Motorschutz durch Thermokontakte
- *integrated control system (EC controller)*
  - *completed system with minimal operating costs, based on use of EC technology*
  - *simple setting and adjustment of the complete system*
  - *speed is 100% infinitely variable*
  - *easy installation (DIN standard flange)*
  - *backward curved impeller*
  - *compact and space saving design*
  - *motor protection by thermal contacts*

**Technische Daten / Technical Data:**

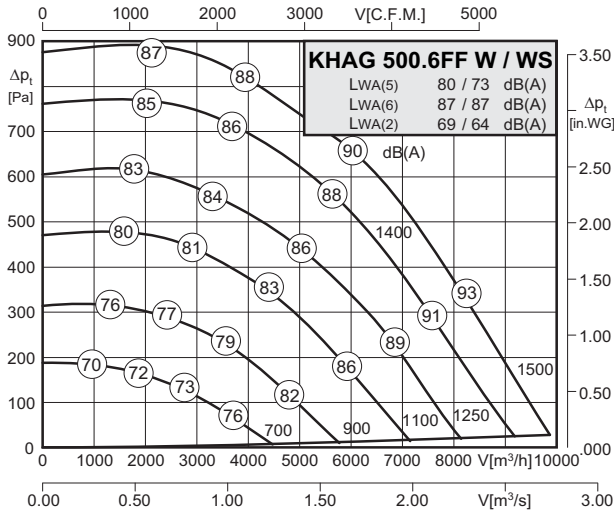

**Energieeinsparung gegenüber dem AC Typ bis zu: / Energy saving rate according to AC type up to:**  
**35%\***

\* im drehzahlgesteuerten Teillastbereich \* at speed controlled partial load range

Type: <b>KHAG 500.6FF W/WS</b>		Art.-No.: <b>D15-50000 / D15-50010</b>	
U	400V (50Hz)	Δp <sub>fa min</sub>	-- Pa
P <sub>1</sub>	2,0 kW	ΔI	-- %
I <sub>N</sub>	3.1 A	I <sub>A</sub> / I <sub>N</sub>	--
n	1500 min <sup>-1</sup>		IP54
C <sub>400V</sub>	-- μF		01.390 a)
t <sub>R</sub>	40 °C		78 kg

**Geräusche / Sound levels:**

LWA <sub>rel</sub> A-bewertet bei V=0,5*V <sub>max</sub> LWA <sub>rel</sub> A-weighted at V=0,5*V <sub>max</sub>		fM [Hz]						
		125	250	500	1K	2K	4K	8K
LWA <sub>2</sub> [dB(A)]	Gehäuse / casing	-10	-3	-7	-8	-11	-17	-25
LWA <sub>5</sub> [dB(A)]	Ansaugseite / inlet side	-20	-9	-5	-6	-7	-13	-22
LWA <sub>6</sub> [dB(A)]	Ausblasseite / outlet side	-19	-9	-7	-4	-7	-13	-23

**Maße / Dimensions:**

(alle Maße in mm / all dimensions in mm)

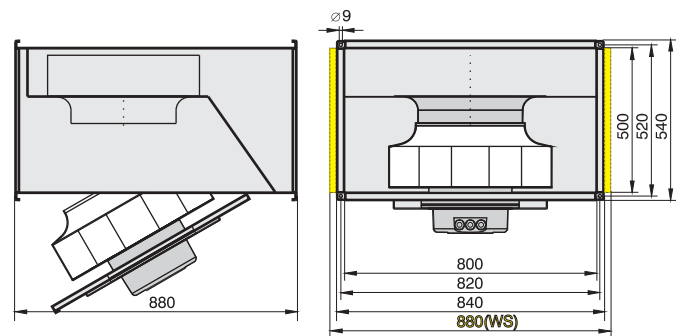

**Schaltbild / Wiring diagram:**

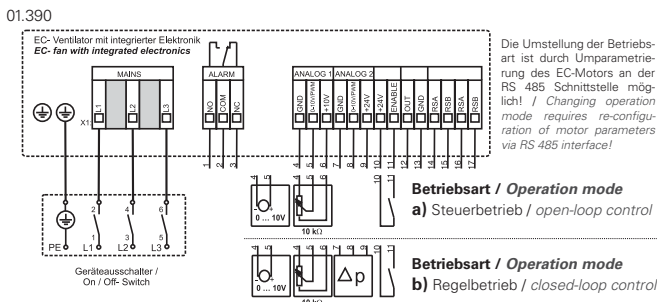

**Zubehör / Accessories:**





- integrierte Regelung (EC-Controller)
  - Komplettsystem mit minimierten Betriebskosten durch den Einsatz von EC-Technik
  - einfache Einregelung und Anpassung an die Anlage
  - stufenlos steuerbar oder regelbar
  - schnelle Montage DIN-Normflansch
  - rückwärtsgekrümmtes Laufrad
  - kompakte, raumsparende Bauart
  - Motorschutz durch Thermokontakte
- *integrated control system (EC controller)*
  - *completed system with minimal operating costs, based on use of EC technology*
  - *simple setting and adjustment of the complete system*
  - *speed is 100% infinitely variable*
  - *easy installation (DIN standard flange)*
  - *backward curved impeller*
  - *compact and space saving design*
  - *motor protection by thermal contacts*

### Technische Daten / Technical Data:

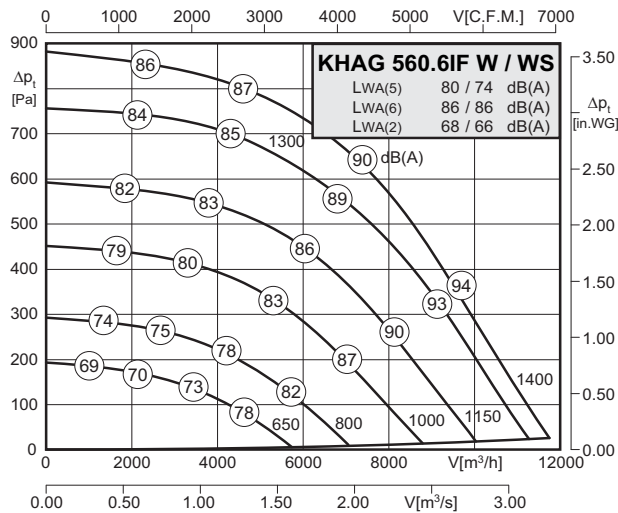

**Energieeinsparung gegenüber dem AC Typ bis zu: / Energy saving rate according to AC type up to:**

**35%\***

\* im drehzahlgesteuerten Teillastbereich \* at speed controlled partial load range

Type: <b>KHAG 560.6IF W/WS</b>		Art.-No.: <b>D15-56000 / D15-56010</b>	
U	400V (50Hz)	$\Delta p_{fa}$ min	- Pa
P <sub>1</sub>	2.4 kW	$\Delta I$	- %
I <sub>N</sub>	3.8 A	I <sub>A</sub> / I <sub>N</sub>	-
n	1400 min <sup>-1</sup>		IP54
C <sub>400V</sub>	- µF		01.390 a)
t <sub>R</sub>	50 °C		91 kg

### Geräusche / Sound levels:

LWArel A-bewertet bei V=0,5*Vmax LWArel A-weighted at V=0,5*Vmax		fM [Hz]						
		125	250	500	1K	2K	4K	8K
LWA2 [dB(A)]	Gehäuse / casing	-6	-5	-8	-12	-19	-26	-29
LWA5 [dB(A)]	Ansaugseite / inlet side	-11	-9	-8	-7	-7	-10	-17
LWA6 [dB(A)]	Ausblasseite / outlet side	-15	-9	-7	-4	-8	-13	-22

### Schaltbild / Wiring diagram:

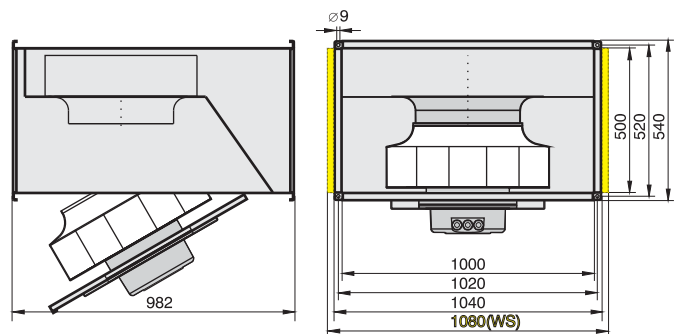
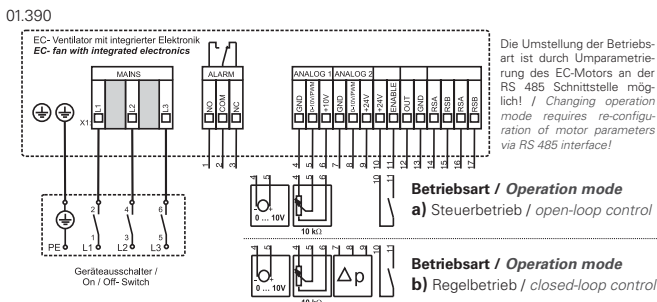

### Zubehör / Accessories:





- schnelle Montage an DIN-Normflansch
- rückwärtsgekrümmtes Laufrad
- in allen Einbaulagen einsetzbar
- kompakte, raumsparende Bauart
- Isolierstoffklasse F
- extrem geringer Anlaufstrom
- Motorschutz durch Thermokontakte
- transformatorisch 100% stufenlos steuerbar
- easy installation (DIN standard flange)
- backward curved impeller
- can be installed in any position
- compact and space saving design
- insulation class F
- extremely low starting current
- motor protection by thermal contacts
- speed is 100% infinitely variable using auto transformers

### Technische Daten / Technical Data:

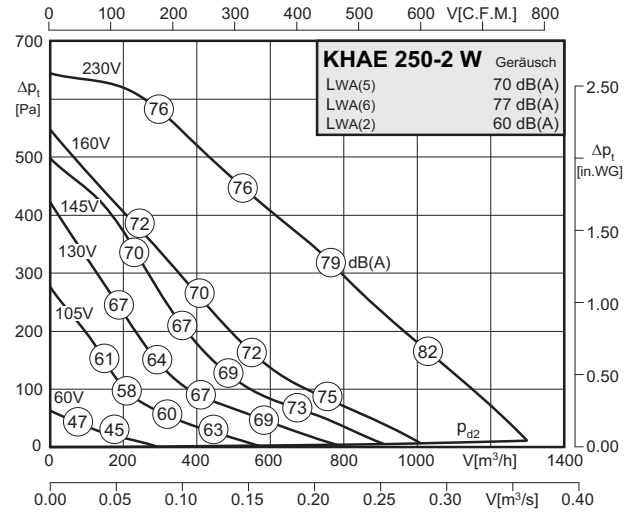
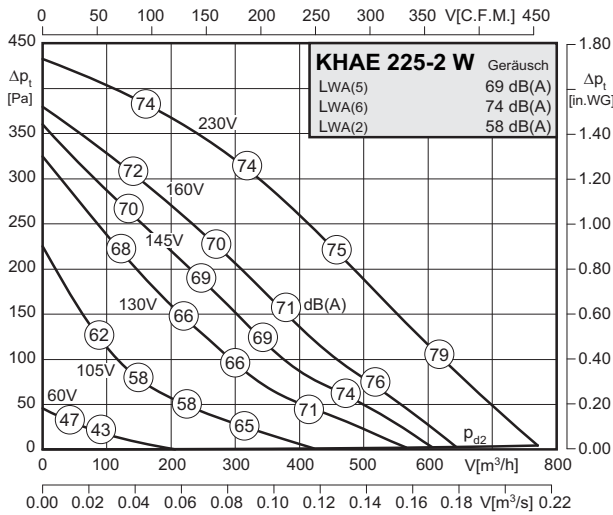

Typ / Type: <b>KHAE 225-2 W</b>		Art.-Nr. / Art.-No.: <b>D14-22500</b>	
U	230V (50Hz)	$\Delta p_{fa \text{ min}}$	-- Pa
P <sub>1</sub>	0,12 kW	$\Delta I$	8 %
I <sub>N</sub>	0,52 A	I <sub>A</sub> / I <sub>N</sub>	1,8
n	2640 min <sup>-1</sup>		IP44
C <sub>400v</sub>	3 $\mu$ F		01.009
t <sub>R</sub>	50 °C		12,5 kg

Typ / Type: <b>KHAE 250-2 W</b>		Art.-Nr. / Art.-No.: <b>D14-25000</b>	
U	230V (50Hz)	$\Delta p_{fa \text{ min}}$	-- Pa
P <sub>1</sub>	0,24 kW	$\Delta I$	2 %
I <sub>N</sub>	1,04 A	I <sub>A</sub> / I <sub>N</sub>	1,6
n	2410 min <sup>-1</sup>		IP44
C <sub>400v</sub>	5 $\mu$ F		01.009
t <sub>R</sub>	45 °C		14 kg

### Geräusche / Sound levels:

LWA <sub>rel</sub> A-bewertet bei V=0,5*V <sub>max</sub> LWA <sub>rel</sub> A-weighted at V=0,5*V <sub>max</sub>	fM [Hz]							
		125	250	500	1K	2K	4K	8K
LWA2 [dB(A)] Gehäuse / casing		-11	-4	-5	-10	-14	-20	-22
LWA5 [dB(A)] Ansaugseite / inlet side		-16	-6	-9	-5	-7	-12	-21
LWA6 [dB(A)] Ausblasseite / outlet side		-23	-10	-5	-8	-6	-11	-21

LWA <sub>rel</sub> A-bewertet bei V=0,5*V <sub>max</sub> LWA <sub>rel</sub> A-weighted at V=0,5*V <sub>max</sub>	fM [Hz]							
		125	250	500	1K	2K	4K	8K
LWA2 [dB(A)] Gehäuse / casing		-13	-7	-4	-7	-12	-18	-20
LWA5 [dB(A)] Ansaugseite / inlet side		-17	-7	-8	-4	-8	-10	-16
LWA6 [dB(A)] Ausblasseite / outlet side		-24	-13	-4	-6	-5	-10	-17

### Schaltbild / Wiring diagram:

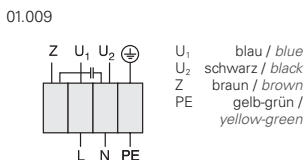

### Maße / Dimensions: (alle Maße in mm / all dimensions in mm)

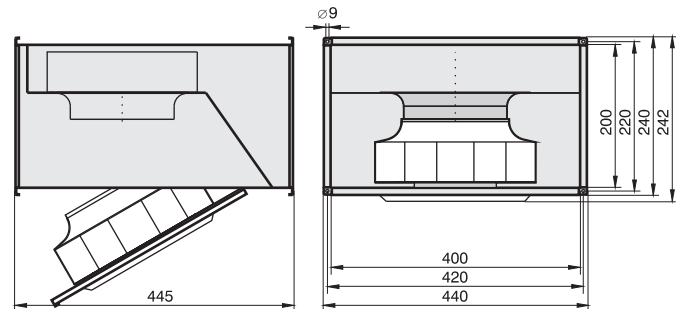

### Zubehör / Accessories:







- schnelle Montage an DIN-Normflansch
- rückwärtsgekrümmtes Laufrad
- in allen Einbaulagen einsetzbar
- kompakte, raumsparende Bauart
- Isolierstoffklasse F
- extrem geringer Anlaufstrom
- Motorschutz durch Thermokontakte
- transformatorisch 100% stufenlos steuerbar
- easy installation (DIN standard flange)
- backward curved impeller
- can be installed in any position
- compact and space saving design
- insulation class F
- extremely low starting current
- motor protection by thermal contacts
- speed is 100% infinitely variable using auto transformers

### Technische Daten / Technical Data:

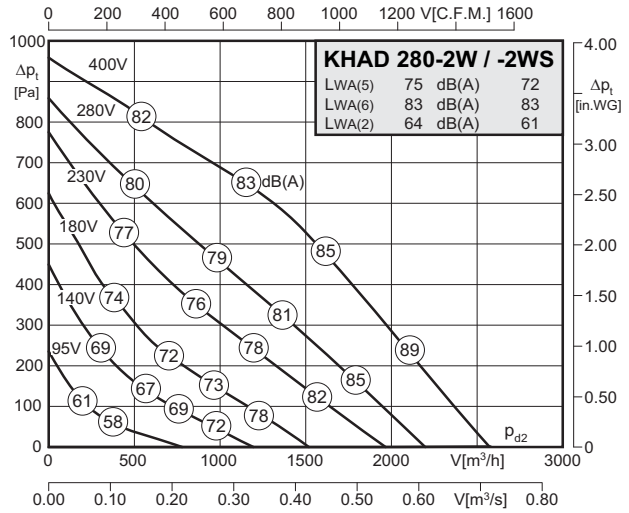
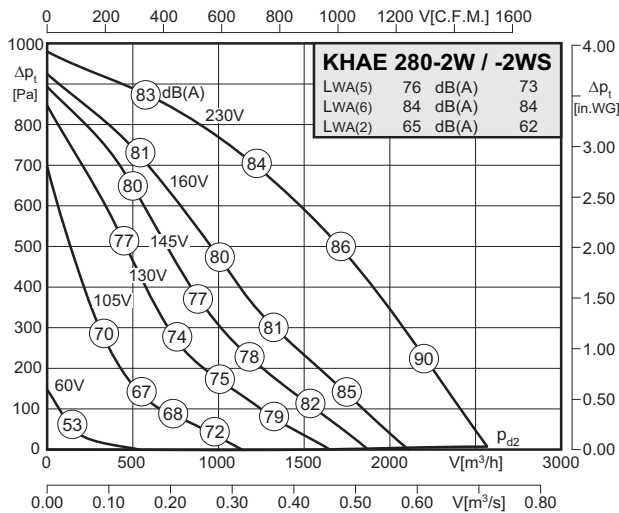

Typ / Type: <b>KHAE 280-2W(S)</b>		Art.-No. : D14-28000 / D14-28010	
U	230V (50Hz)	$\Delta p_{fa}$ min	- Pa
P <sub>1</sub>	0.73 kW	$\Delta i$	16 %
I <sub>N</sub>	3.2 A	I <sub>A</sub> / I <sub>N</sub>	2.1
n	2580 min <sup>-1</sup>		IP54
C <sub>400v</sub>	14 $\mu$ F		01.024
t <sub>R</sub>	60 °C		23,5 / 26,5 kg

Typ / Type: <b>KHAD 280-2W(S)</b>		Art.-No. : D14-28050 / D14-28060	
U	400V (50Hz)	$\Delta p_{fa}$ min	- Pa
P <sub>1</sub>	0.62 kW	$\Delta i$	4 %
I <sub>N</sub>	1.0 A	I <sub>A</sub> / I <sub>N</sub>	2.5
n	2440 min <sup>-1</sup>		IP54
C <sub>400v</sub>	- $\mu$ F		01.006
t <sub>R</sub>	65 °C		21,5 / 24,5 kg

### Geräusche / Sound levels:

LWArel A-bewertet bei V=0,5*Vmax		fM [Hz]						
LWArel A-weighted at V=0,5*Vmax		125	250	500	1K	2K	4K	8K
LWA2 [dB(A)]	Gehäuse / casing	-12	-1	-6	-10	-15	-20	-26
LWA5 [dB(A)]	Ansaugseite / inlet side	-19	-4	-6	-5	-8	-13	-21
LWA6 [dB(A)]	Ausblasseite / outlet side	-26	-7	-5	-6	-6	-13	-22

LWArel A-bewertet bei V=0,5*Vmax		fM [Hz]						
LWArel A-weighted at V=0,5*Vmax		125	250	500	1K	2K	4K	8K
LWA2 [dB(A)]	Gehäuse / casing	-12	-1	-6	-10	-15	-20	-26
LWA5 [dB(A)]	Ansaugseite / inlet side	-19	-4	-6	-5	-8	-13	-21
LWA6 [dB(A)]	Ausblasseite / outlet side	-26	-7	-5	-6	-6	-13	-22

### Schaltbild / Wiring diagram:

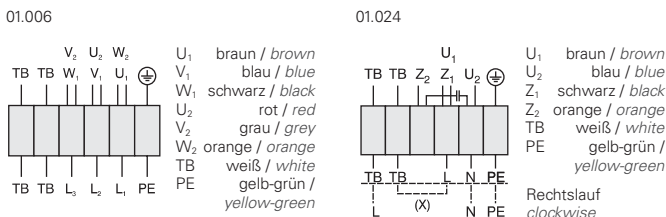

### Maße / Dimensions: (alle Maße in mm / all dimensions in mm)

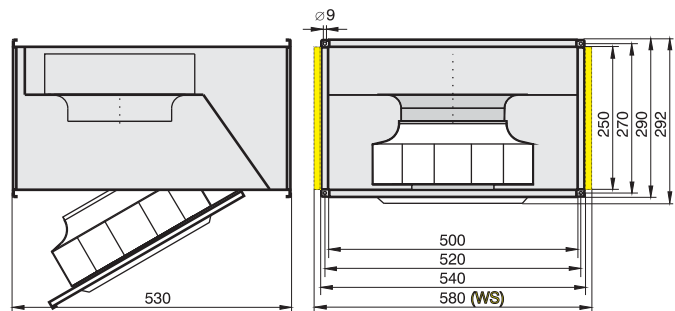

### Zubehör / Accessories:





- schnelle Montage an DIN-Normflansch
- rückwärtsgekrümmtes Laufrad
- in allen Einbaulagen einsetzbar
- kompakte, raumsparende Bauart
- Isolierstoffklasse F
- extrem geringer Anlaufstrom
- Motorschutz durch Thermokontakte
- transformatorisch 100% stufenlos steuerbar
- easy installation (DIN standard flange)
- backward curved impeller
- can be installed in any position
- compact and space saving design
- insulation class F
- extremely low starting current
- motor protection by thermal contacts
- speed is 100% infinitely variable using auto transformers

### Technische Daten / Technical Data:

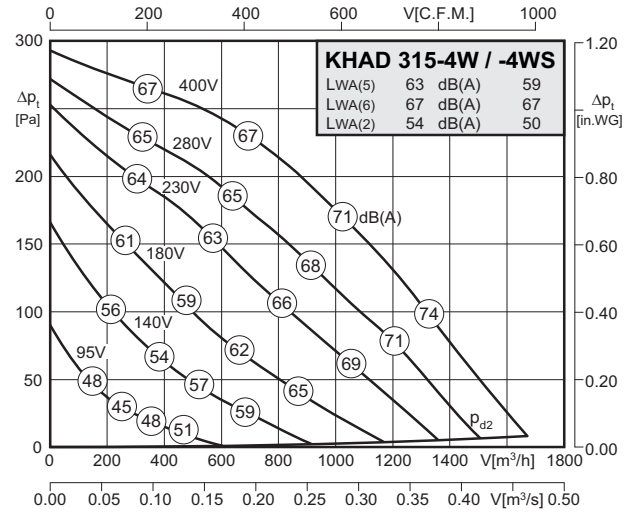
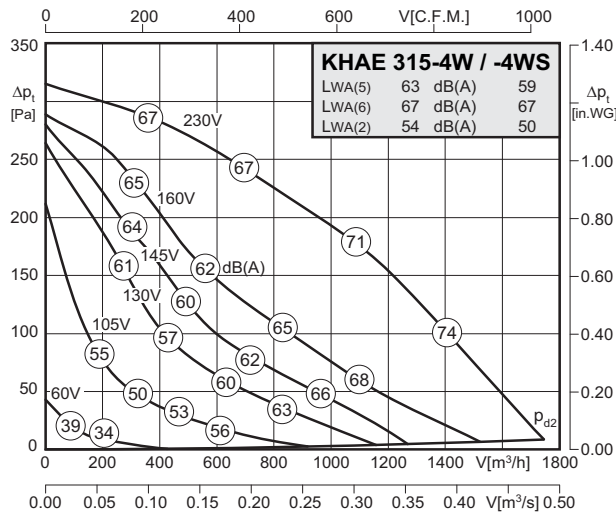

Typ / Type: KHAE 315-4 W(S)		Art.-No. : D14-31500 / D14-31510	
U	230V (50Hz)	Δpfa min	-- Pa
P1	0,165 kW	ΔI	4 %
IN	0.73 A	IA / IN	1.9
n	1325 min-1	▲	IP54
C400v	4 μF	✱	01.024
tR	50 °C	■	20/23 kg

Typ / Type: KHAD 315-4 W(S)		Art.-No. : D14-31550 / D14-31560	
U	400V (50Hz)	Δpfa min	-- Pa
P1	0,15 kW	ΔI	-- %
IN	0.33 A	IA / IN	2.8
n	1340 min-1	▲	IP54
C400v	-- μF	✱	01.006
tR	70 °C	■	20/23 kg

### Geräusche / Sound levels:

LWAref A-bewertet bei V=0,5*Vmax LWAref A-weighted at V=0,5*Vmax	fM [Hz]	fM [Hz]						
		125	250	500	1K	2K	4K	8K
LWA2 [dB(A)] Gehäuse / casing		-5	-3	-11	-12	-14	-19	-27
LWA5 [dB(A)] Ansaugseite / inlet side		-8	-7	-6	-6	-9	-16	-28
LWA6 [dB(A)] Ausblasseite / outlet side		-15	-7	-5	-5	-6	-14	-21

LWAref A-bewertet bei V=0,5*Vmax LWAref A-weighted at V=0,5*Vmax	fM [Hz]	fM [Hz]						
		125	250	500	1K	2K	4K	8K
LWA2 [dB(A)] Gehäuse / casing		-5	-3	-11	-12	-14	-19	-27
LWA5 [dB(A)] Ansaugseite / inlet side		-8	-7	-6	-6	-9	-16	-28
LWA6 [dB(A)] Ausblasseite / outlet side		-15	-7	-5	-5	-6	-14	-21

### Schaltbild / Wiring diagram:

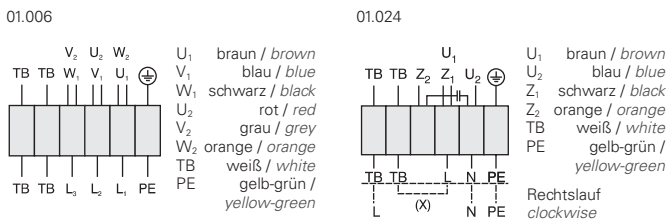

### Maße / Dimensions: (alle Maße in mm / all dimensions in mm)

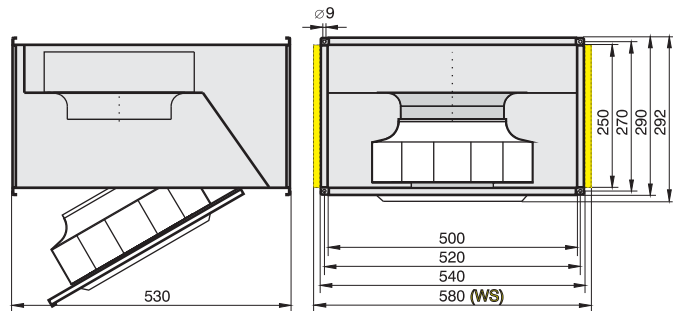

### Zubehör / Accessories:





- schnelle Montage an DIN-Normflansch
- rückwärtsgekrümmtes Laufrad
- in allen Einbaulagen einsetzbar
- kompakte, raumsparende Bauart
- Isolierstoffklasse F
- extrem geringer Anlaufstrom
- Motorschutz durch Thermokontakte
- transformatorisch 100% stufenlos steuerbar
- easy installation (DIN standard flange)
- backward curved impeller
- can be installed in any position
- compact and space saving design
- insulation class F
- extremely low starting current
- motor protection by thermal contacts
- speed is 100% infinitely variable using auto transformers

### Technische Daten / Technical Data:

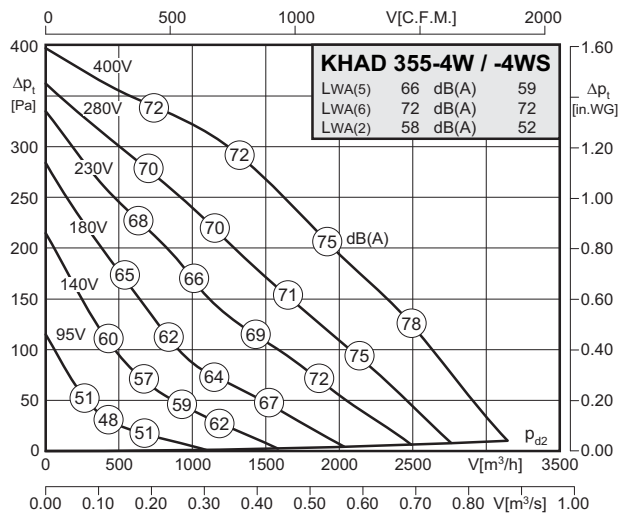
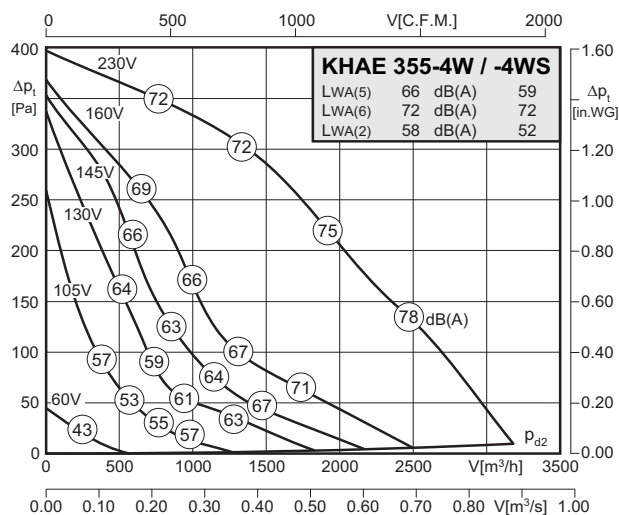

Typ / Type: KHAE 355-4 W(S)		Art.-No. : D14-35500 / D14-35510	
U	230V (50Hz)	Δpfa min	- Pa
P1	0.32 kW	Δl	8 %
IN	1.45 A	IA / IN	2.0
n	1300 min-1	▲	IP54
C400v	6 μF	✳	01.024
tr	40 °C	■	32 / 35 kg

Typ / Type: KHAD 355-4 W(S)		Art.-No. : D14-35550 / D14-35560	
U	400V (50Hz)	Δpfa min	- Pa
P1	0.29 kW	Δl	- %
IN	0.55 A	IA / IN	2.8
n	1300 min-1	▲	IP54
C400v	- μF	✳	01.006
tr	60 °C	■	31 / 34 kg

### Geräusche / Sound levels:

LWArel A-bewertet bei V=0,5*Vmax LWArel A-weighted at V=0,5*Vmax	fM [Hz]						
	125	250	500	1K	2K	4K	8K
LWA2 [dB(A)] Gehäuse / casing	-4	-5	-12	-12	-15	-21	-27
LWA5 [dB(A)] Ansaugseite / inlet side	-11	-5	-9	-9	-7	-11	-20
LWA6 [dB(A)] Ausblasseite / outlet side	-10	-9	-6	-5	-6	-13	-22

LWArel A-bewertet bei V=0,5*Vmax LWArel A-weighted at V=0,5*Vmax	fM [Hz]						
	125	250	500	1K	2K	4K	8K
LWA2 [dB(A)] Gehäuse / casing	-4	-5	-12	-12	-15	-21	-27
LWA5 [dB(A)] Ansaugseite / inlet side	-11	-5	-9	-9	-7	-11	-20
LWA6 [dB(A)] Ausblasseite / outlet side	-10	-9	-6	-5	-6	-13	-22

### Schaltbild / Wiring diagram:

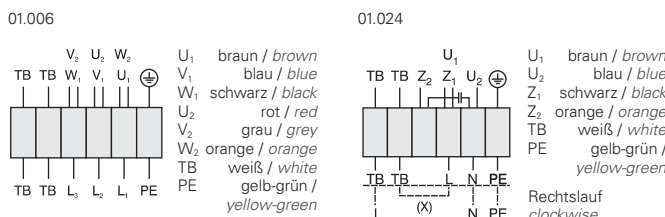

### Maße / Dimensions: (alle Maße in mm / all dimensions in mm)

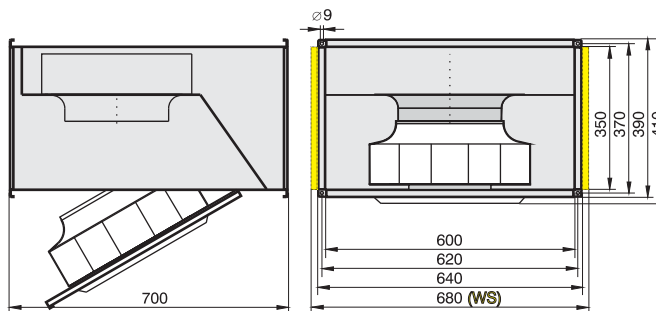

### Zubehör / Accessories:





- schnelle Montage an DIN-Normflansch
- rückwärtsgekrümmtes Laufrad
- in allen Einbaulagen einsetzbar
- kompakte, raumsparende Bauart
- Isolierstoffklasse F
- extrem geringer Anlaufstrom
- Motorschutz durch Thermokontakte
- transformatorisch 100% stufenlos steuerbar
- easy installation (DIN standard flange)
- backward curved impeller
- can be installed in any position
- compact and space saving design
- insulation class F
- extremely low starting current
- motor protection by thermal contacts
- speed is 100% infinitely variable using auto transformers

### Technische Daten / Technical Data:

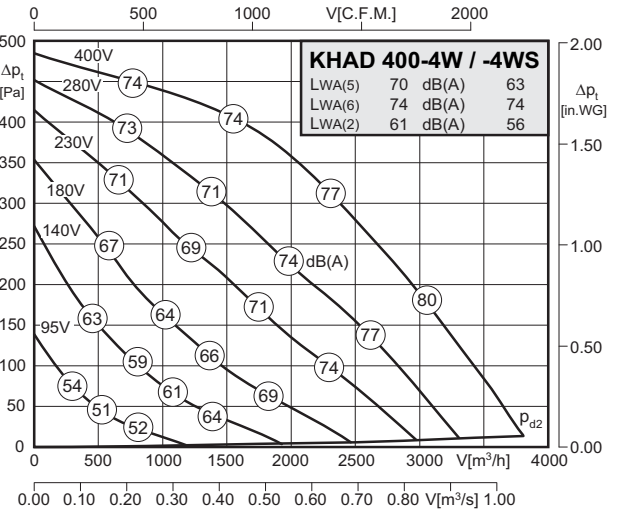
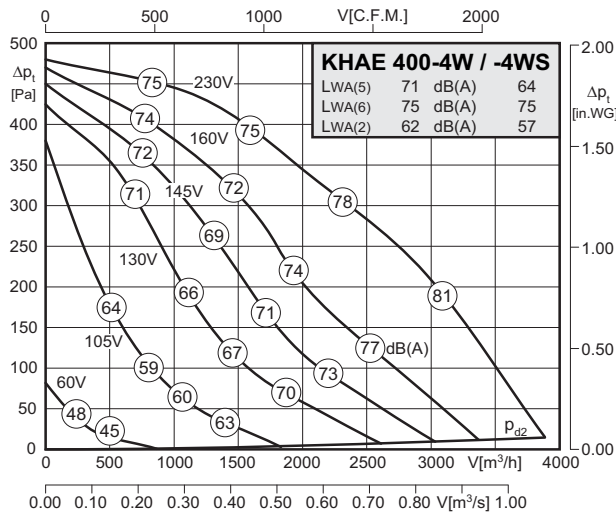

Typ / Type: <b>KHAE 400-4 W(S)</b>		Art.-No. : D14-40000 / D14-40010	
U	230V (50Hz)	$\Delta p_{fa}$ min	-- Pa
P <sub>1</sub>	0,54 kW	$\Delta I$	12 %
I <sub>N</sub>	2,60 A	I <sub>A</sub> / I <sub>N</sub>	2,5
n	1370 min <sup>-1</sup>		IP54
C <sub>400v</sub>	12 $\mu$ F		01.024
t <sub>R</sub>	45 °C		35 / 38 kg

Typ / Type: <b>KHAD 400-4 W(S)</b>		Art.-No. : D14-40050 / D14-40060	
U	400V (50Hz)	$\Delta p_{fa}$ min	-- Pa
P <sub>1</sub>	0,49 kW	$\Delta I$	10 %
I <sub>N</sub>	0,90 A	I <sub>A</sub> / I <sub>N</sub>	3,2
n	1310 min <sup>-1</sup>		IP54
C <sub>400v</sub>	-- $\mu$ F		01.006
t <sub>R</sub>	40 °C		33 / 36 kg

### Geräusche / Sound levels:

LWAref A-bewertet bei V=0,5*Vmax LWAref A-weighted at V=0,5*Vmax	fM [Hz]							
		125	250	500	1K	2K	4K	8K
LWA2 [dB(A)] Gehäuse / casing		-4	-3	-11	-13	-18	-21	-28
LWA5 [dB(A)] Ansaugseite / inlet side		-7	-5	-11	-9	-8	-12	-20
LWA6 [dB(A)] Ausblasseite / outlet side		-10	-8	-7	-6	-7	-11	-21

LWAref A-bewertet bei V=0,5*Vmax LWAref A-weighted at V=0,5*Vmax	fM [Hz]							
		125	250	500	1K	2K	4K	8K
LWA2 [dB(A)] Gehäuse / casing		-4	-3	-11	-13	-18	-21	-28
LWA5 [dB(A)] Ansaugseite / inlet side		-7	-5	-11	-9	-8	-12	-20
LWA6 [dB(A)] Ausblasseite / outlet side		-10	-8	-7	-6	-7	-11	-21

### Schaltbild / Wiring diagram:

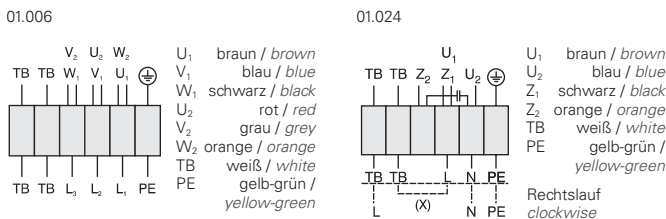

### Maße / Dimensions: (alle Maße in mm / all dimensions in mm)

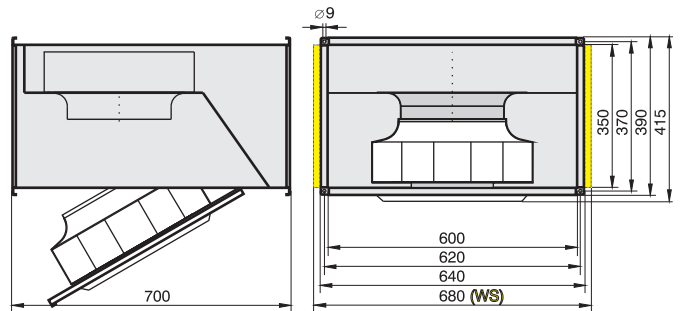

### Zubehör / Accessories:



# Kanalventilatoren (rückwärtsgekrümmt) / Duct Fans (backward curved)

## Baugröße / Size: 450



- schnelle Montage an DIN-Normflansch
- rückwärtsgekrümmtes Laufrad
- in allen Einbaulagen einsetzbar
- kompakte, raumsparende Bauart
- Isolierstoffklasse F
- extrem geringer Anlaufstrom
- Motorschutz durch Thermokontakte
- transformatorisch 100% stufenlos steuerbar
- easy installation (DIN standard flange)
- backward curved impeller
- can be installed in any position
- compact and space saving design
- insulation class F
- extremely low starting current
- motor protection by thermal contacts
- speed is 100% infinitely variable using auto transformers

### Technische Daten / Technical Data:

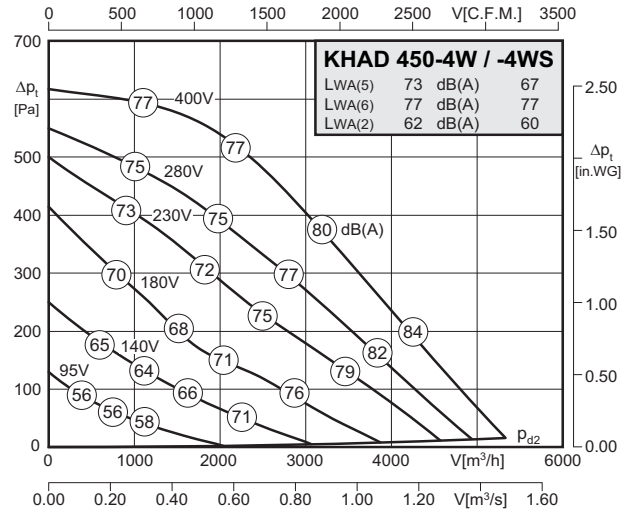
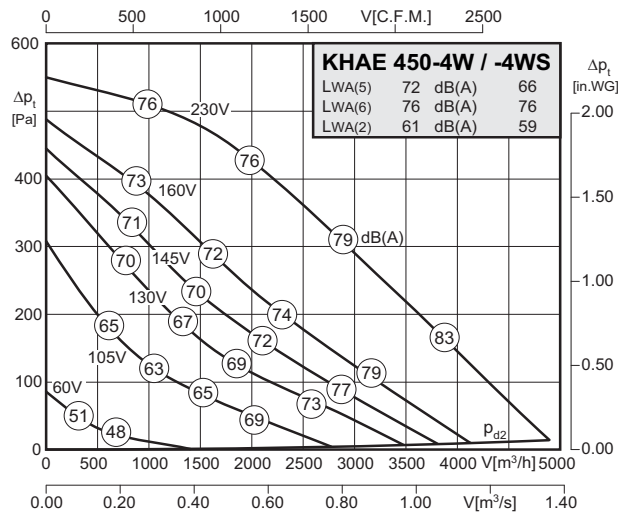

Typ / Type: KHAE 450-4 W(S)		Art.-No. : D14-45000 / D14-45010	
U	230V (50Hz)	ΔPfa min	- Pa
P1	0.71 kW	Δi	11 %
IN	3.25 A	IA / IN	2.0
n	1265 min-1	▲	IP54
C400v	16 μF	✳	01.024
tr	50 °C	■	47 / 50 kg

Typ / Type: KHAD 450-4 W(S)		Art.-No. : D14-45050 / D14-45060	
U	400V (50Hz)	ΔPfa min	- Pa
P1	0.78 kW	Δi	5 %
IN	1.55 A	IA / IN	2.5
n	1355 min-1	▲	IP54
C400v	- μF	✳	01.006
tr	55 °C	■	47 / 50 kg

### Geräusche / Sound levels:

LWArel A-bewertet bei V=0,5*Vmax LWArel A-weighted at V=0,5*Vmax		fM [Hz]						
		125	250	500	1K	2K	4K	8K
LWA2 [dB(A)]	Gehäuse / casing	-7	-4	-8	-11	-15	-20	-27
LWA5 [dB(A)]	Ansaugseite / inlet side	-14	-9	-3	-7	-8	-14	-22
LWA6 [dB(A)]	Ausblasseite / outlet side	-15	-9	-7	-5	-8	-13	-23

LWArel A-bewertet bei V=0,5*Vmax LWArel A-weighted at V=0,5*Vmax		fM [Hz]						
		125	250	500	1K	2K	4K	8K
LWA2 [dB(A)]	Gehäuse / casing	-7	-4	-8	-11	-15	-20	-27
LWA5 [dB(A)]	Ansaugseite / inlet side	-14	-9	-3	-7	-8	-14	-22
LWA6 [dB(A)]	Ausblasseite / outlet side	-15	-9	-7	-5	-8	-13	-23

### Schaltbild / Wiring diagram:

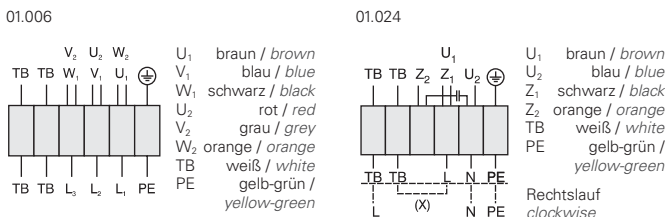

### Maße / Dimensions: (alle Maße in mm / all dimensions in mm)

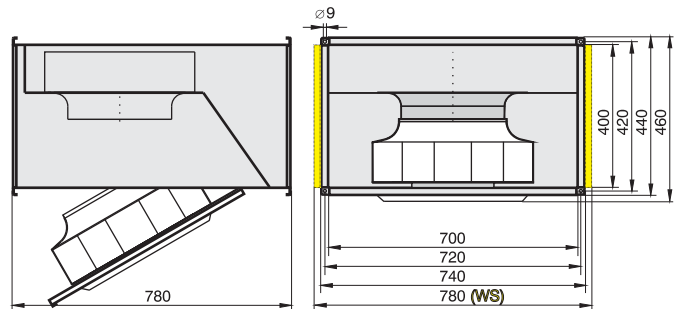

### Zubehör / Accessories:



R(T)/RTD	MSE/MSD	ED	TE/TD	GS	KD	FKV	GF	VK	VKJ	KFB
Seite/Page	Seite/Page	Seite/Page	Seite/Page	Seite/Page	Seite/Page	Seite/Page	Seite/Page	Seite/Page	Seite/Page	Seite/Page
382 ff, 392	378	402	400	404	424	424	425	425	426	426



- schnelle Montage an DIN-Normflansch
- rückwärtsgekrümmtes Laufrad
- in allen Einbaulagen einsetzbar
- kompakte, raumsparende Bauart
- Isolierstoffklasse F
- extrem geringer Anlaufstrom
- Motorschutz durch Thermokontakte
- transformatorisch 100% stufenlos steuerbar
- easy installation (DIN standard flange)
- backward curved impeller
- can be installed in any position
- compact and space saving design
- insulation class F
- extremely low starting current
- motor protection by thermal contacts
- speed is 100% infinitely variable using auto transformers

### Technische Daten / Technical Data:

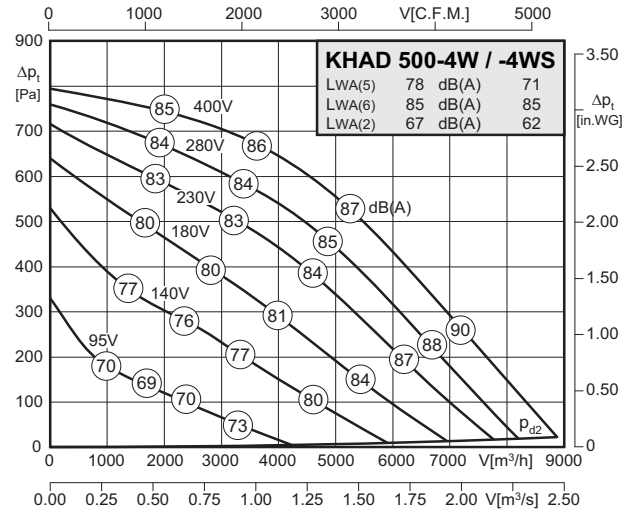
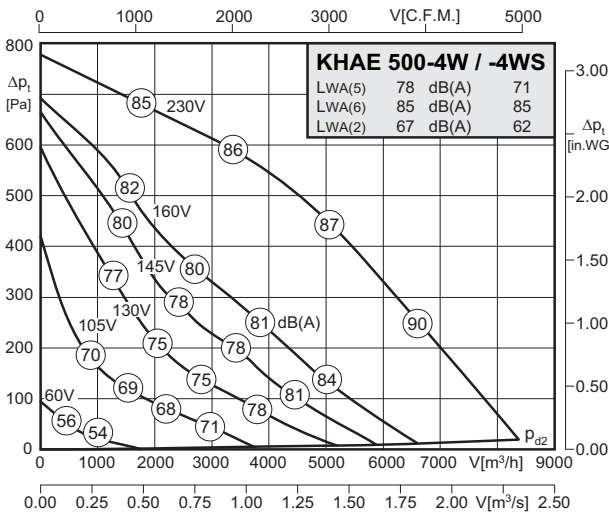

Typ / Type: KHAE 500-4 W(S)		Art.-No. : D14-50000 / D14-50010	
U	230V (50Hz)	$\Delta p_{fa}$ min	-- Pa
P <sub>1</sub>	1,62 kW	$\Delta I$	8 %
I <sub>N</sub>	7,30 A	I <sub>A</sub> / I <sub>N</sub>	2,2
n	1300 min <sup>-1</sup>		IP54
C <sub>400v</sub>	30 $\mu$ F		01.024
t <sub>R</sub>	40 °C		69 / 72 kg

Typ / Type: KHAD 500-4 W(S)		Art.-No. : D14-50050 / D14-50060	
U	400V (50Hz)	$\Delta p_{fa}$ min	-- Pa
P <sub>1</sub>	1,70 kW	$\Delta I$	9.5 %
I <sub>N</sub>	3,50 A	I <sub>A</sub> / I <sub>N</sub>	4,3
n	1390 min <sup>-1</sup>		IP54
C <sub>400v</sub>	-- $\mu$ F		01.006
t <sub>R</sub>	55 °C		69 / 72 kg

### Geräusche / Sound levels:

LWArel A-bewertet bei V=0,5*Vmax LWArel A-weighted at V=0,5*Vmax	fM [Hz]							
		125	250	500	1K	2K	4K	8K
LWA2 [dB(A)] Gehäuse / casing		-10	-3	-7	-8	-11	-17	-25
LWA5 [dB(A)] Ansaugseite / inlet side		-20	-9	-5	-6	-7	-13	-22
LWA6 [dB(A)] Ausblasseite / outlet side		-19	-9	-7	-4	-7	-13	-23

LWArel A-bewertet bei V=0,5*Vmax LWArel A-weighted at V=0,5*Vmax	fM [Hz]							
		125	250	500	1K	2K	4K	8K
LWA2 [dB(A)] Gehäuse / casing		-10	-3	-7	-8	-11	-17	-25
LWA5 [dB(A)] Ansaugseite / inlet side		-20	-9	-5	-6	-7	-13	-22
LWA6 [dB(A)] Ausblasseite / outlet side		-19	-9	-7	-4	-7	-13	-23

### Schaltbild / Wiring diagram:

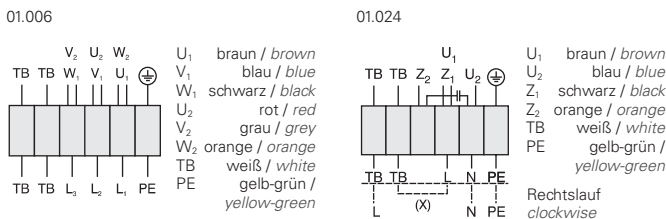

### Maße / Dimensions: (alle Maße in mm / all dimensions in mm)

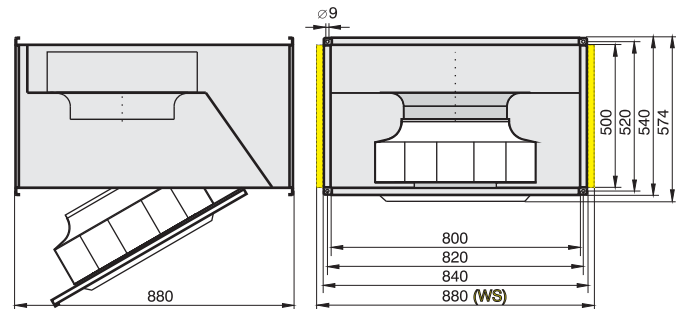

### Zubehör / Accessories:





- schnelle Montage an DIN-Normflansch
  - rückwärtsgekrümmtes Laufrad
  - in allen Einbaulagen einsetzbar
  - kompakte, raumsparende Bauart
  - Isolierstoffklasse F
  - extrem geringer Anlaufstrom
  - Motorschutz durch Thermokontakte
  - transformatorisch 100% stufenlos steuerbar
- easy installation (DIN standard flange)
  - backward curved impeller
  - can be installed in any position
  - compact and space saving design
  - insulation class F
  - extremely low starting current
  - motor protection by thermal contacts
  - speed is 100% infinitely variable using auto transformers

### Technische Daten / Technical Data:

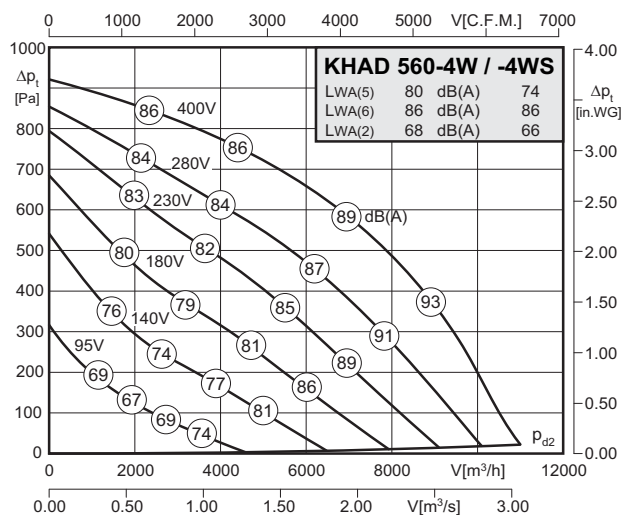

Typ / Type: KHAD 560-4 W(S)		Art.-No. : D14-56050 / D14-56060	
U	400V (50Hz)	ΔP <sub>fa min</sub>	- Pa
P <sub>1</sub>	2.40 kW	ΔI	6 %
I <sub>N</sub>	4.50 A	I <sub>A</sub> / I <sub>N</sub>	4.2
n	1340 min <sup>-1</sup>		IP54
C <sub>400V</sub>	- μF		01.006
t <sub>R</sub>	45 °C		96 kg

### Geräusche / Sound levels:

LWA <sub>rel</sub> A-bewertet bei V=0,5*V <sub>max</sub> LWA <sub>rel</sub> A-weighted at V=0,5*V <sub>max</sub>		fM [Hz]						
		125	250	500	1K	2K	4K	8K
LWA <sub>2</sub> [dB(A)]	Gehäuse / casing	-6	-5	-8	-12	-19	-26	-29
LWA <sub>5</sub> [dB(A)]	Ansaugseite / inlet side	-11	-9	-8	-7	-7	-10	-17
LWA <sub>6</sub> [dB(A)]	Ausblasseite / outlet side	-15	-9	-7	-4	-8	-13	-22

### Schaltbild / Wiring diagram:

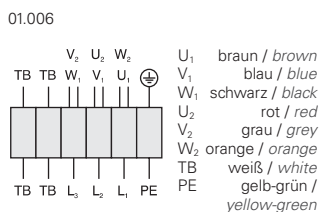

### Zubehör / Accessories:



### Maße / Dimensions: (alle Maße in mm / all dimensions in mm)

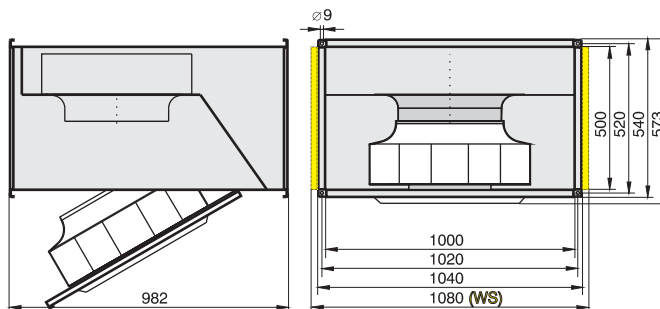



- schnelle Montage an DIN-Normflansch
- vorwärtsgekrümmtes Laufrad
- in allen Einbaulagen einsetzbar
- kompakte, raumsparende Bauart
- Isolierstoffklasse F
- extrem geringer Anlaufstrom
- Motorschutz durch Thermokontakte
- transformatorisch 100% stufenlos steuerbar
- easy installation (DIN standard flange)
- forward curved impeller
- can be installed in any position
- compact and space saving design
- insulation class F
- extremely low starting currents
- motor protection by thermal contacts
- speed is 100% infinitely variable using auto transformers

### Technische Daten / Technical Data:

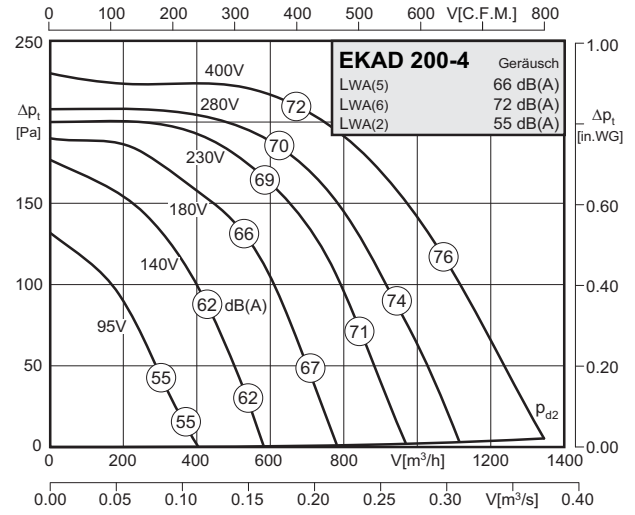
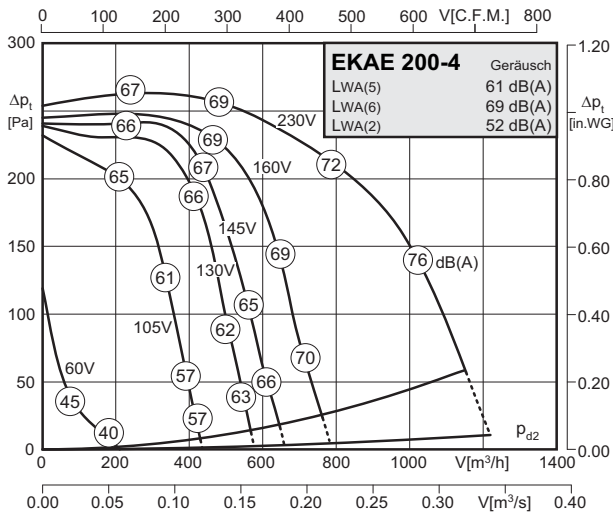

Typ / Type: <b>EKAE 200-4</b>		Art.-Nr. / Art.-No.: <b>D00-20000</b>	
U	230V (50Hz)	Δpfa min	50 Pa
P1	0,29 kW	ΔI	10 %
IN	1,25 A	IA / IN	1,8
n	1260 min-1	▲	IP54
C400v	6 μF	★	01.024
tR	50 °C	■	13 kg

Typ / Type: <b>EKAD 200-4</b>		Art.-Nr. / Art.-No.: <b>D00-20050</b>	
U	400V (50Hz)	Δpfa min	– Pa
P1	0,33 kW	ΔI	– %
IN	0,61 A	IA / IN	2,0
n	1270 min-1	▲	IP54
C400v	– μF	★	01.006
tR	60 °C	■	13 kg

### Geräusche / Sound levels:

LWArel A-bewertet bei V=0,5*Vmax LWArel A-weighted at V=0,5*Vmax	fM [Hz]						
	125	250	500	1K	2K	4K	8K
Gehäuse 4-polig / casing 4-pole	-5	-7	-9	-7	-12	-17	-24
Ansaugseite 4-polig / inlet side 4-pole	-13	-15	-6	-5	-7	-9	-18
Ausblasseite 4-polig / outlet side 4-pole	-16	-14	-8	-5	-6	-7	-17

LWArel A-bewertet bei V=0,5*Vmax LWArel A-weighted at V=0,5*Vmax	fM [Hz]						
	125	250	500	1K	2K	4K	8K
Gehäuse 4-polig / casing 4-pole	-5	-7	-9	-7	-12	-17	-24
Ansaugseite 4-polig / inlet side 4-pole	-13	-15	-6	-5	-7	-9	-18
Ausblasseite 4-polig / outlet side 4-pole	-16	-14	-8	-5	-6	-7	-17

### Schaltbild / Wiring diagram:

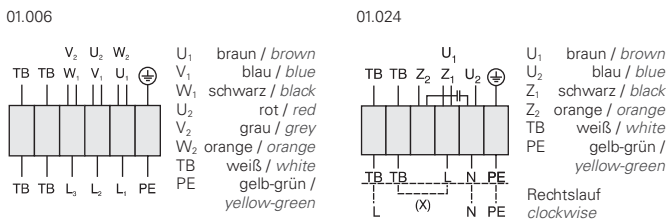

### Maße / Dimensions: (alle Maße in mm / all dimensions in mm)

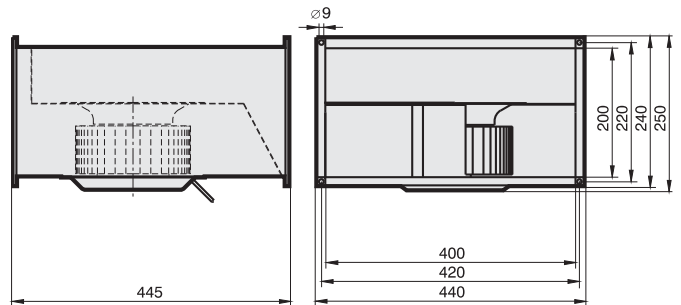

### Zubehör / Accessories:







- schnelle Montage an DIN-Normflansch
- vorwärtsgekrümmtes Laufrad
- in allen Einbaulagen einsetzbar
- kompakte, raumsparende Bauart
- Isolierstoffklasse F
- extrem geringer Anlaufstrom
- Motorschutz durch Thermokontakte
- transformatorisch 100% stufenlos steuerbar
- easy installation (DIN standard flange)
- forward curved impeller
- can be installed in any position
- compact and space saving design
- insulation class F
- extremely low starting currents
- motor protection by thermal contacts
- speed is 100% infinitely variable using auto transformers

### Technische Daten / Technical Data:

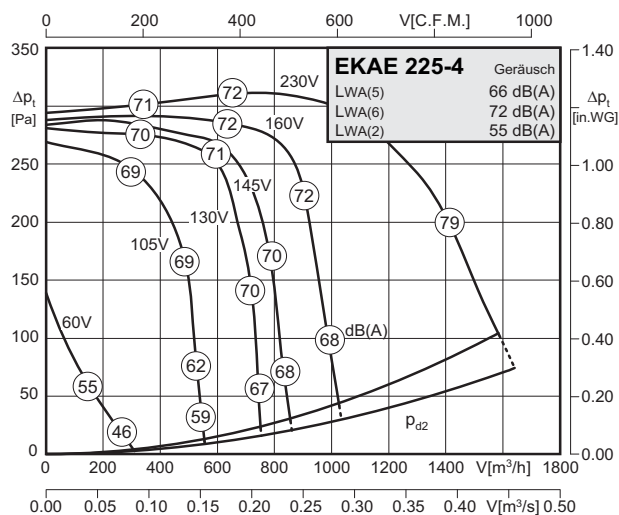

Typ / Type: <b>EKA 225-4</b>		Art.-Nr. / Art.-No.: <b>D00-22500</b>	
U	230V (50Hz)	ΔP <sub>fa</sub> min	35 Pa
P <sub>1</sub>	0.49 kW	ΔI	11 %
I <sub>N</sub>	2.20 A	I <sub>A</sub> / I <sub>N</sub>	1.8
n	1220 min <sup>-1</sup>		IP54
C <sub>400V</sub>	8 μF		01.024
t <sub>R</sub>	40 °C		19,5 kg

### Geräusche / Sound levels:

LWA <sub>rel</sub> A-bewertet bei V=0,5*V <sub>max</sub> LWA <sub>rel</sub> A-weighted at V=0,5*V <sub>max</sub>	fM [Hz]						
	125	250	500	1K	2K	4K	8K
Gehäuse 4-polig / casing 4-pole	-5	-7	-9	-7	-12	-17	-24
Ansaugseite 4-polig / inlet side 4-pole	-13	-15	-6	-5	-7	-9	-18
Ausblasseite 4-polig / outlet side 4-pole	-16	-14	-8	-5	-6	-7	-17

### Schaltbild / Wiring diagram:

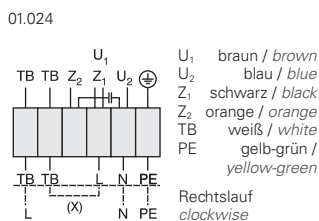

### Zubehör / Accessories:



### Maße / Dimensions: (alle Maße in mm / all dimensions in mm)

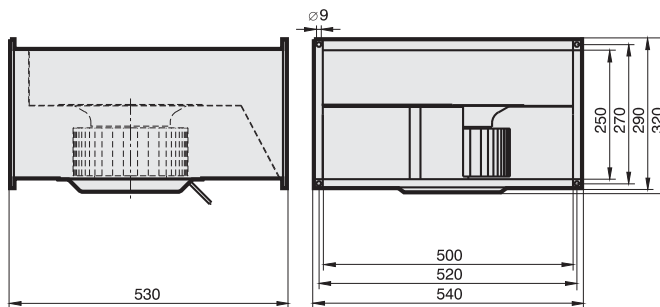



- schnelle Montage an DIN-Normflansch
- vorwärtsgekrümmtes Laufrad
- in allen Einbaulagen einsetzbar
- kompakte, raumsparende Bauart
- Isolierstoffklasse F
- extrem geringer Anlaufstrom
- Motorschutz durch Thermokontakte
- transformatorisch 100% stufenlos steuerbar
- easy installation (DIN standard flange)
- forward curved impeller
- can be installed in any position
- compact and space saving design
- insulation class F
- extremely low starting currents
- motor protection by thermal contacts
- speed is 100% infinitely variable using auto transformers

### Technische Daten / Technical Data:

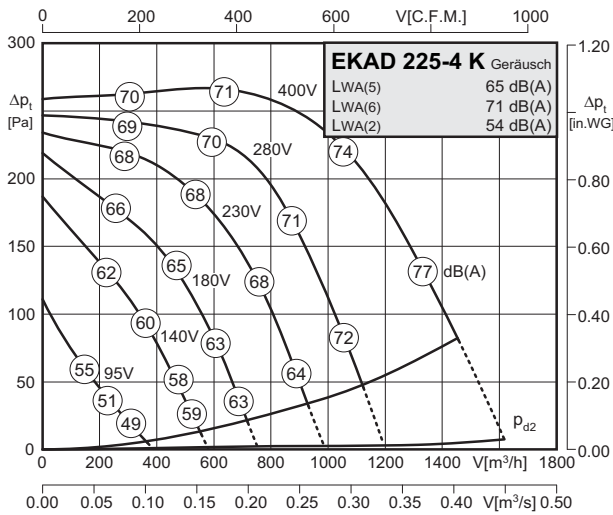

Typ / Type: <b>EKAD 225-4 K</b>		Art.-Nr. / Art.-No.: <b>D00-22550</b>	
U	400V (50Hz)	Δp <sub>fa min</sub>	75 Pa
P <sub>1</sub>	0,41 kW	ΔI	-- %
I <sub>N</sub>	0,68 A	I <sub>A</sub> / I <sub>N</sub>	2,0
n	1150 min <sup>-1</sup>	▲	IP54
C <sub>400V</sub>	-- μF	★	01.006
t <sub>R</sub>	40 °C	■	18 kg

### Geräusche / Sound levels:

LWA <sub>rel</sub> A-bewertet bei V=0,5*V <sub>max</sub> LWA <sub>rel</sub> A-weighted at V=0,5*V <sub>max</sub>	fM [Hz]						
	125	250	500	1K	2K	4K	8K
Gehäuse 4-polig / casing 4-pole	-5	-7	-9	-7	-12	-17	-24
Ansaugseite 4-polig / inlet side 4-pole	-13	-15	-6	-5	-7	-9	-18
Ausblasseite 4-polig / outlet side 4-pole	-16	-14	-8	-5	-6	-7	-17

### Schaltbild / Wiring diagram:

01.006

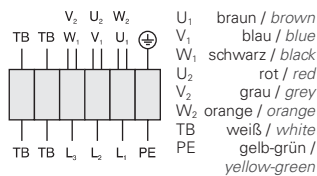

### Maße / Dimensions: (alle Maße in mm / all dimensions in mm)

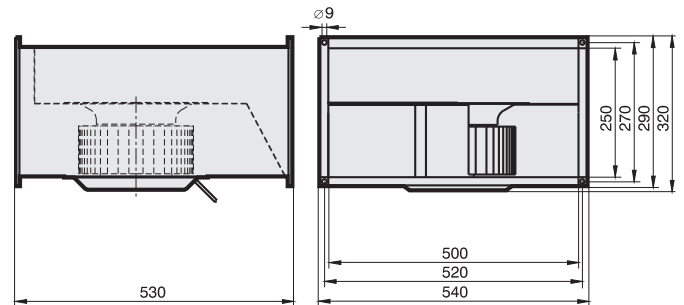

### Zubehör / Accessories:



# Kanalventilatoren (vorwärtsgekrümmt) / Duct Fans (forward curved)

## Baugröße / Size: 250



- schnelle Montage an DIN-Normflansch
- vorwärtsgekrümmtes Laufrad
- in allen Einbaulagen einsetzbar
- kompakte, raumsparende Bauart
- Isolierstoffklasse F
- extrem geringer Anlaufstrom
- Motorschutz durch Thermokontakte
- transformatorisch 100% stufenlos steuerbar
- easy installation (DIN standard flange)
- forward curved impeller
- can be installed in any position
- compact and space saving design
- insulation class F
- extremely low starting currents
- motor protection by thermal contacts
- speed is 100% infinitely variable using auto transformers

### Technische Daten / Technical Data:

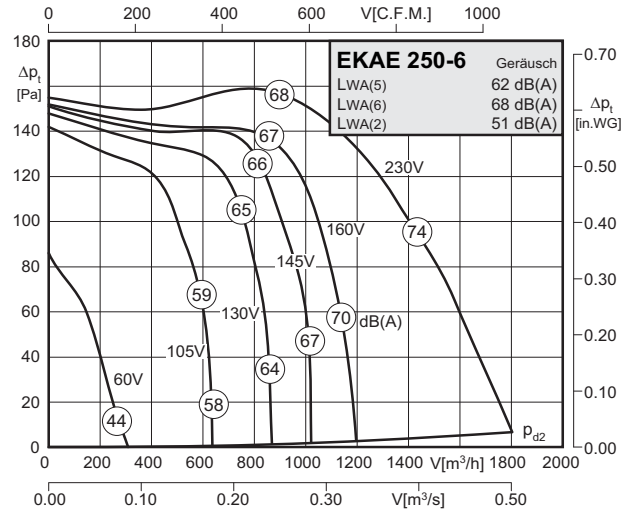
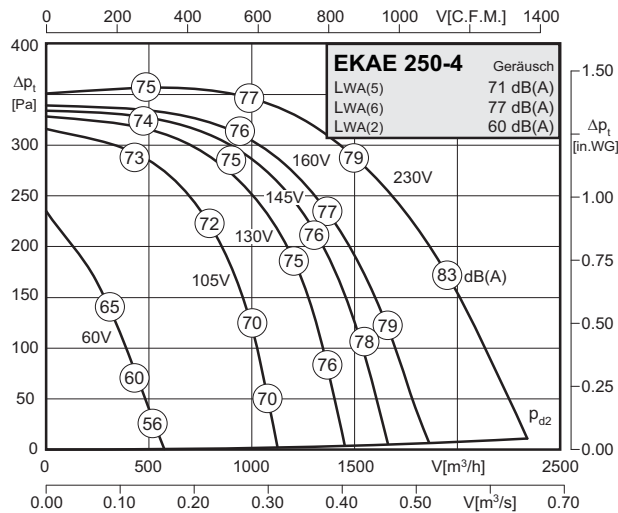

Typ / Type: <b>EKAE 250-4</b>		Art.-Nr. / Art.-No.: <b>D00-25000</b>	
U	230V (50Hz)	Δp <sub>fa</sub> min	- Pa
P <sub>1</sub>	0.73 kW	Δl	5 %
I <sub>N</sub>	3.3 A	I <sub>A</sub> / I <sub>N</sub>	1.8
n	1250 min <sup>-1</sup>	▲	IP54
C <sub>400V</sub>	16 μF	✳	01.024
t <sub>R</sub>	65 °C	■	25,5 kg

Typ / Type: <b>EKAE 250-6</b>		Art.-Nr. / Art.-No.: <b>D00-25003</b>	
U	230V (50Hz)	Δp <sub>fa</sub> min	- Pa
P <sub>1</sub>	0.32 kW	Δl	- %
I <sub>N</sub>	1.40 A	I <sub>A</sub> / I <sub>N</sub>	1.6
n	820 min <sup>-1</sup>	▲	IP54
C <sub>400V</sub>	5 μF	✳	01.024
t <sub>R</sub>	60 °C	■	24 kg

### Geräusche / Sound levels:

LWA <sub>rel</sub> A-bewertet bei V=0,5*V <sub>max</sub> LWA <sub>rel</sub> A-weighted at V=0,5*V <sub>max</sub>	fM [Hz]						
	125	250	500	1K	2K	4K	8K
Gehäuse 4-polig / casing 4-pole	-5	-7	-9	-7	-12	-17	-24
Ansaugseite 4-polig / inlet side 4-pole	-13	-15	-6	-5	-7	-9	-18
Ausblasseite 4-polig / outlet side 4-pole	-16	-14	-8	-5	-6	-7	-17

LWA <sub>rel</sub> A-bewertet bei V=0,5*V <sub>max</sub> LWA <sub>rel</sub> A-weighted at V=0,5*V <sub>max</sub>	fM [Hz]						
	125	250	500	1K	2K	4K	8K
Gehäuse 6-polig / casing 6-pole	-10	-9	-4	-7	-9	-14	-21
Ansaugseite 6-polig / inlet side 6-pole	-17	-15	-7	-6	-6	-7	-14
Ausblasseite 6-polig / outlet side 6-pole	-22	-13	-7	-6	-5	-7	-15

### Schaltbild / Wiring diagram:

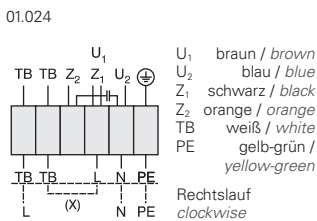

### Maße / Dimensions: (alle Maße in mm / all dimensions in mm)

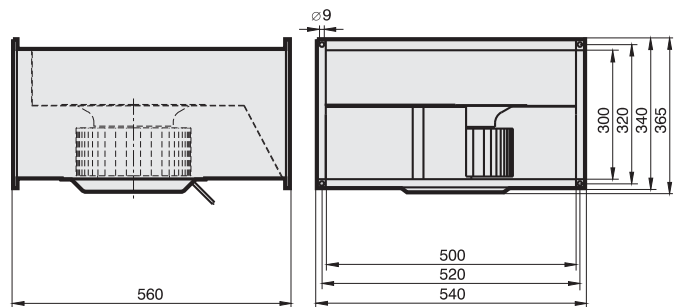

### Zubehör / Accessories:





- schnelle Montage an DIN-Normflansch
- vorwärtsgekrümmtes Laufrad
- in allen Einbaulagen einsetzbar
- kompakte, raumsparende Bauart
- Isolierstoffklasse F
- extrem geringer Anlaufstrom
- Motorschutz durch Thermokontakte
- transformatorisch 100% stufenlos steuerbar
- easy installation (DIN standard flange)
- forward curved impeller
- can be installed in any position
- compact and space saving design
- insulation class F
- extremely low starting currents
- motor protection by thermal contacts
- speed is 100% infinitely variable using auto transformers

### Technische Daten / Technical Data:

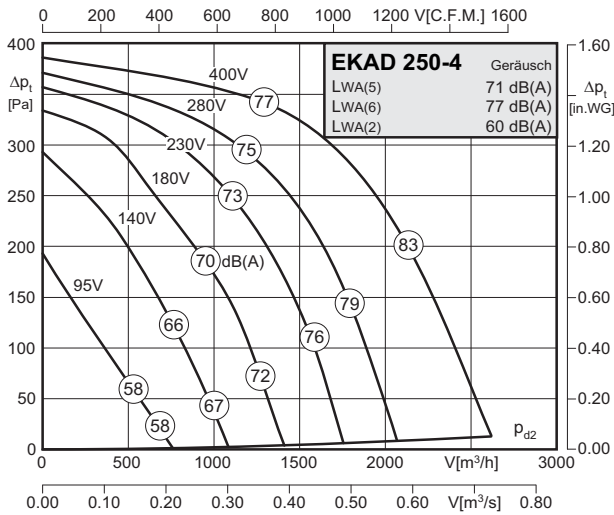

Typ / Type: EKAD 250-4		Art.-Nr. / Art.-No.: D00-25050	
U	400V (50Hz)	$\Delta p_{fa \text{ min}}$	-- Pa
P <sub>1</sub>	0,83 kW	$\Delta I$	-- %
I <sub>N</sub>	1,55 A	I <sub>A</sub> / I <sub>N</sub>	2,2
n	1210 min <sup>-1</sup>		IP54
C <sub>400V</sub>	-- $\mu$ F		01.006
t <sub>R</sub>	40 °C		23,5 kg

### Geräusche / Sound levels:

LWA <sub>rel</sub> A-bewertet bei V=0,5*V <sub>max</sub> LWA <sub>rel</sub> A-weighted at V=0,5*V <sub>max</sub>	fM [Hz]						
	125	250	500	1K	2K	4K	8K
Gehäuse 4-polig / casing 4-pole	-5	-7	-9	-7	-12	-17	-24
Ansaugseite 4-polig / inlet side 4-pole	-13	-15	-6	-5	-7	-9	-18
Ausblasseite 4-polig / outlet side 4-pole	-16	-14	-8	-5	-6	-7	-17

### Schaltbild / Wiring diagram:

01.006

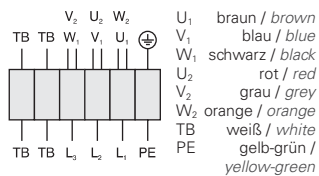

### Maße / Dimensions: (alle Maße in mm / all dimensions in mm)

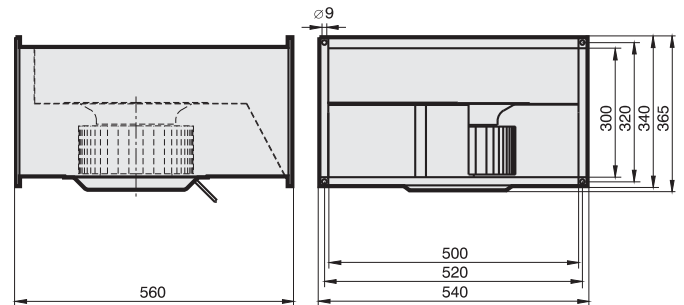

### Zubehör / Accessories:



<b>RTD</b>	<b>MSD</b>	<b>ED</b>	<b>TD</b>	<b>GS</b>	<b>KD</b>	<b>FKV</b>	<b>GF</b>	<b>VK</b>	<b>VKJ</b>	<b>KFB</b>
Seite/Page 392	Seite/Page 378	Seite/Page 402	Seite/Page 400	Seite/Page 404	Seite/Page 424	Seite/Page 424	Seite/Page 425	Seite/Page 425	Seite/Page 426	Seite/Page 426

# Kanalventilatoren (vorwärtsgekrümmt) / Duct Fans (forward curved)

## Baugröße / Size: 280



- schnelle Montage an DIN-Normflansch
- vorwärtsgekrümmtes Laufrad
- in allen Einbaulagen einsetzbar
- kompakte, raumsparende Bauart
- Isolierstoffklasse F
- extrem geringer Anlaufstrom
- Motorschutz durch Thermokontakte
- transformatorisch 100% stufenlos steuerbar
- easy installation (DIN standard flange)
- forward curved impeller
- can be installed in any position
- compact and space saving design
- insulation class F
- extremely low starting currents
- motor protection by thermal contacts
- speed is 100% infinitely variable using auto transformers

### Technische Daten / Technical Data:

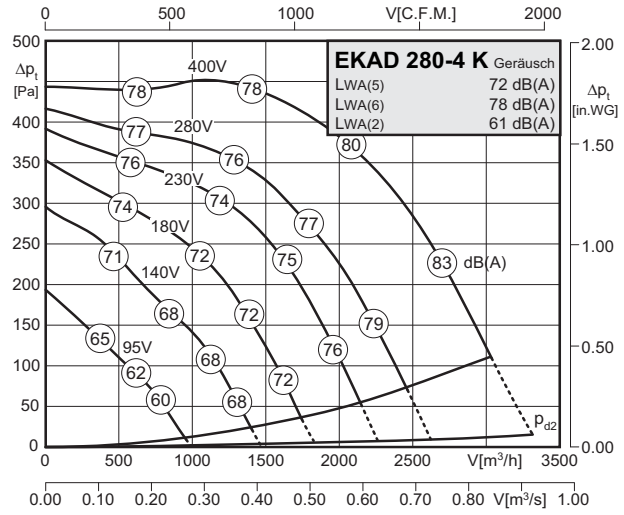
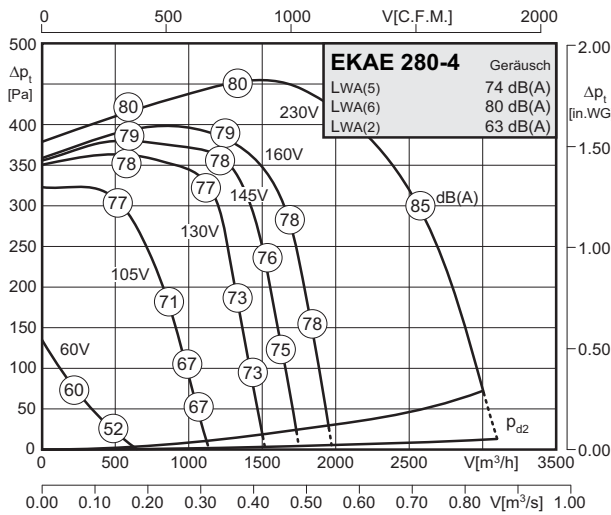

Typ / Type: <b>EKA 280-4</b>		Art.-Nr. / Art.-No.: <b>D00-28000</b>	
U	230V (50Hz)	$\Delta p_{fa}$ min	60 Pa
P <sub>1</sub>	1.25 kW	$\Delta I$	- %
I <sub>N</sub>	5.8 A	I <sub>A</sub> / I <sub>N</sub>	1.3
n	1070 min <sup>-1</sup>		IP54
C <sub>400V</sub>	20 $\mu$ F		01.024
t <sub>R</sub>	40 °C		28 kg

Typ / Type: <b>EKAD 280-4 K</b>		Art.-Nr. / Art.-No.: <b>D00-28050</b>	
U	400V (50Hz)	$\Delta p_{fa}$ min	100 Pa
P <sub>1</sub>	1.1 kW	$\Delta I$	- %
I <sub>N</sub>	2.0 A	I <sub>A</sub> / I <sub>N</sub>	2.4
n	1110 min <sup>-1</sup>		IP54
C <sub>400V</sub>	- $\mu$ F		01.006
t <sub>R</sub>	40 °C		28 kg

### Geräusche / Sound levels:

LWArel A-bewertet bei V=0,5*Vmax LWArel A-weighted at V=0,5*Vmax	fM [Hz]						
	125	250	500	1K	2K	4K	8K
Gehäuse 4-polig / casing 4-pole	-5	-7	-9	-7	-12	-17	-24
Ansaugseite 4-polig / inlet side 4-pole	-13	-15	-6	-5	-7	-9	-18
Ausblasseite 4-polig / outlet side 4-pole	-16	-14	-8	-5	-6	-7	-17

LWArel A-bewertet bei V=0,5*Vmax LWArel A-weighted at V=0,5*Vmax	fM [Hz]						
	125	250	500	1K	2K	4K	8K
Gehäuse 4-polig / casing 4-pole	-5	-7	-9	-7	-12	-17	-24
Ansaugseite 4-polig / inlet side 4-pole	-13	-15	-6	-5	-7	-9	-18
Ausblasseite 4-polig / outlet side 4-pole	-16	-14	-8	-5	-6	-7	-17

### Schaltbild / Wiring diagram:

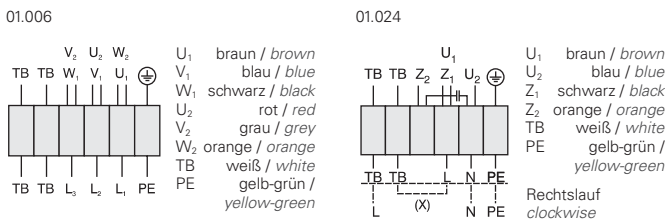

### Maße / Dimensions: (alle Maße in mm / all dimensions in mm)

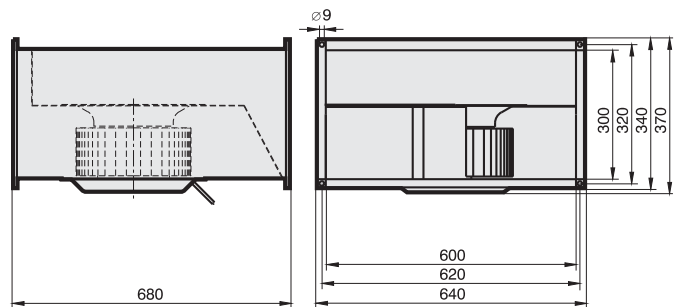

### Zubehör / Accessories:





- schnelle Montage an DIN-Normflansch
- vorwärtsgekrümmtes Laufrad
- in allen Einbaulagen einsetzbar
- kompakte, raumsparende Bauart
- Isolierstoffklasse F
- extrem geringer Anlaufstrom
- Motorschutz durch Thermokontakte
- transformatorisch 100% stufenlos steuerbar
- easy installation (DIN standard flange)
- forward curved impeller
- can be installed in any position
- compact and space saving design
- insulation class F
- extremely low starting currents
- motor protection by thermal contacts
- speed is 100% infinitely variable using auto transformers

### Technische Daten / Technical Data:

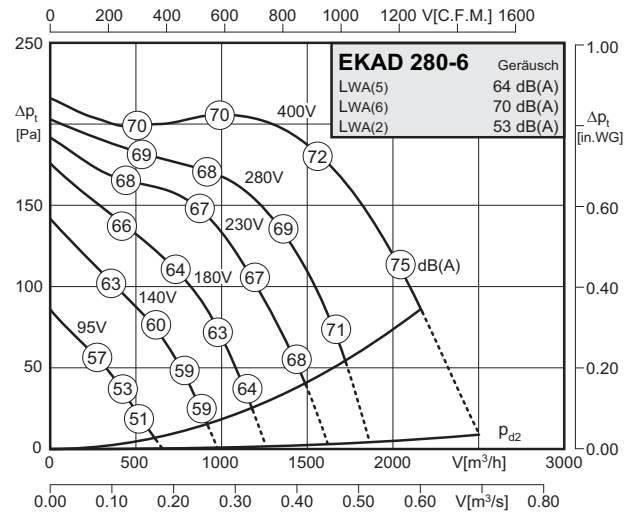
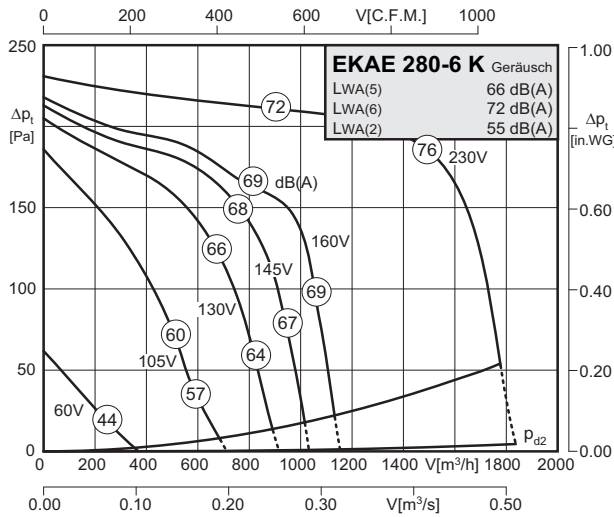

Typ / Type: <b>EKAE 280-6 K</b>		Art.-Nr. / Art.-No.: <b>D00-28003</b>	
U	230V (50Hz)	Δp <sub>fa</sub> min	50 Pa
P <sub>1</sub>	0,38 kW	ΔI	-- %
I <sub>N</sub>	1,7 A	I <sub>A</sub> / I <sub>N</sub>	1,3
n	660 min <sup>-1</sup>	▲	IP54
C <sub>400v</sub>	6 μF	★	01.024
t <sub>R</sub>	40 °C	■	25 kg

Typ / Type: <b>EKAD 280-6</b>		Art.-Nr. / Art.-No.: <b>D00-28053</b>	
U	400V (50Hz)	Δp <sub>fa</sub> min	80 Pa
P <sub>1</sub>	0,43 kW	ΔI	-- %
I <sub>N</sub>	0,75 A	I <sub>A</sub> / I <sub>N</sub>	2,1
n	790 min <sup>-1</sup>	▲	IP54
C <sub>400v</sub>	-- μF	★	01.006
t <sub>R</sub>	40 °C	■	25 kg

### Geräusche / Sound levels:

LWA <sub>rel</sub> A-bewertet bei V=0,5*V <sub>max</sub> LWA <sub>rel</sub> A-weighted at V=0,5*V <sub>max</sub>	f [Hz]						
	125	250	500	1K	2K	4K	8K
Gehäuse 6-polig / casing 6-pole	-10	-9	-4	-7	-9	-14	-21
Ansaugseite 6-polig / inlet side 6-pole	-17	-15	-7	-6	-6	-7	-14
Ausblasseite 6-polig / outlet side 6-pole	-22	-13	-7	-6	-5	-7	-15

LWA <sub>rel</sub> A-bewertet bei V=0,5*V <sub>max</sub> LWA <sub>rel</sub> A-weighted at V=0,5*V <sub>max</sub>	f [Hz]						
	125	250	500	1K	2K	4K	8K
Gehäuse 6-polig / casing 6-pole	-10	-9	-4	-7	-9	-14	-21
Ansaugseite 6-polig / inlet side 6-pole	-17	-15	-7	-6	-6	-7	-14
Ausblasseite 6-polig / outlet side 6-pole	-22	-13	-7	-6	-5	-7	-15

### Schaltbild / Wiring diagram:

01.006

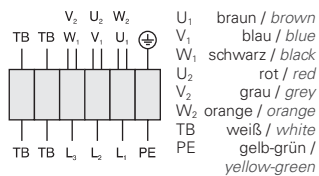

01.024

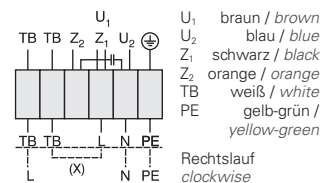

### Maße / Dimensions: (alle Maße in mm / all dimensions in mm)

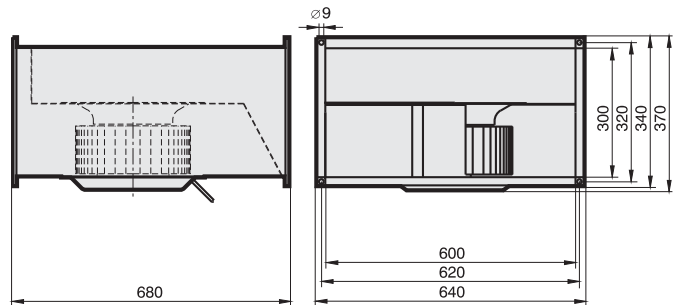

### Zubehör / Accessories:



R(T)/RTD	MSE/MSD	ED	TE/TD	GS	KD	FKV	GF	VK	VKJ	KFB
Seite/Page	Seite/Page	Seite/Page	Seite/Page	Seite/Page	Seite/Page	Seite/Page	Seite/Page	Seite/Page	Seite/Page	Seite/Page
382 ff, 392	378	402	400	404	424	424	425	425	426	426

# Kanalventilatoren (vorwärtsgekrümmt) / Duct Fans (forward curved)

## Baugröße / Size: 315



- schnelle Montage an DIN-Normflansch
- vorwärtsgekrümmtes Laufrad
- in allen Einbaulagen einsetzbar
- kompakte, raumsparende Bauart
- Isolierstoffklasse F
- extrem geringer Anlaufstrom
- Motorschutz durch Thermokontakte
- transformatorisch 100% stufenlos steuerbar
- easy installation (DIN standard flange)
- forward curved impeller
- can be installed in any position
- compact and space saving design
- insulation class F
- extremely low starting currents
- motor protection by thermal contacts
- speed is 100% infinitely variable using auto transformers

### Technische Daten / Technical Data:

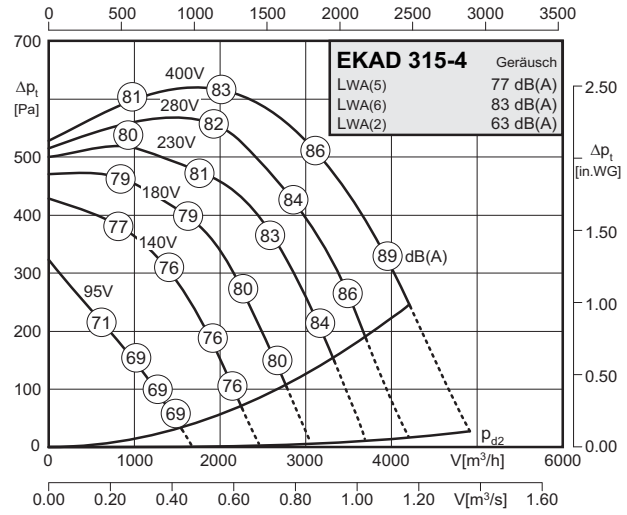
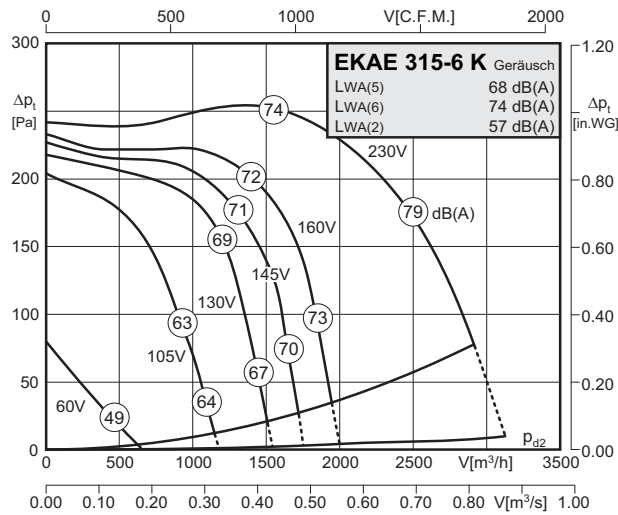

Typ / Type: <b>EKAE 315-6 K</b>		Art.-Nr. / Art.-No.: <b>D00-31500</b>	
U	230V (50Hz)	Δp <sub>fa</sub> min	65 Pa
P <sub>1</sub>	0.72 kW	Δl	- %
I <sub>N</sub>	3.30 A	I <sub>A</sub> / I <sub>N</sub>	1.5
n	730 min <sup>-1</sup>	⚠	IP54
C <sub>400v</sub>	12 μF	✳	01.024
t <sub>R</sub>	40 °C	🔌	34 kg

Typ / Type: <b>EKAD 315-4</b>		Art.-Nr. / Art.-No.: <b>D00-31550</b>	
U	400V (50Hz)	Δp <sub>fa</sub> min	230 Pa
P <sub>1</sub>	2.0 kW	Δl	- %
I <sub>N</sub>	4.1 A	I <sub>A</sub> / I <sub>N</sub>	3.5
n	1320 min <sup>-1</sup>	⚠	IP54
C <sub>400v</sub>	- μF	✳	01.006
t <sub>R</sub>	40 °C	🔌	44 kg

### Geräusche / Sound levels:

LWA <sub>rel</sub> A-bewertet bei V=0,5*V <sub>max</sub> LWA <sub>rel</sub> A-weighted at V=0,5*V <sub>max</sub>	fM [Hz]						
	125	250	500	1K	2K	4K	8K
Gehäuse 6-polig / casing 6-pole	-10	-9	-4	-7	-9	-14	-21
Ansaugseite 6-polig / inlet side 6-pole	-17	-15	-7	-6	-6	-7	-14
Ausblasseite 6-polig / outlet side 6-pole	-22	-13	-7	-6	-5	-7	-15

LWA <sub>rel</sub> A-bewertet bei V=0,5*V <sub>max</sub> LWA <sub>rel</sub> A-weighted at V=0,5*V <sub>max</sub>	fM [Hz]						
	125	250	500	1K	2K	4K	8K
Gehäuse 4-polig / casing 4-pole	-5	-7	-9	-7	-12	-17	-24
Ansaugseite 4-polig / inlet side 4-pole	-13	-15	-6	-5	-7	-9	-18
Ausblasseite 4-polig / outlet side 4-pole	-16	-14	-8	-5	-6	-7	-17

### Schaltbild / Wiring diagram:

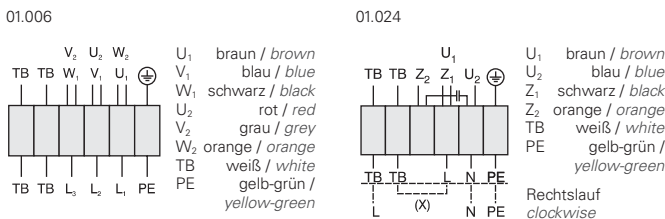

### Maße / Dimensions: (alle Maße in mm / all dimensions in mm)

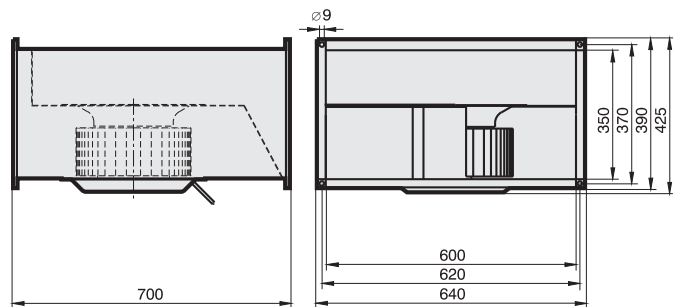

### Zubehör / Accessories:





- schnelle Montage an DIN-Normflansch
- vorwärtsgekrümmtes Laufrad
- in allen Einbaulagen einsetzbar
- kompakte, raumsparende Bauart
- Isolierstoffklasse F
- extrem geringer Anlaufstrom
- Motorschutz durch Thermokontakte
- transformatorisch 100% stufenlos steuerbar
- easy installation (DIN standard flange)
- forward curved impeller
- can be installed in any position
- compact and space saving design
- insulation class F
- extremely low starting currents
- motor protection by thermal contacts
- speed is 100% infinitely variable using auto transformers

### Technische Daten / Technical Data:

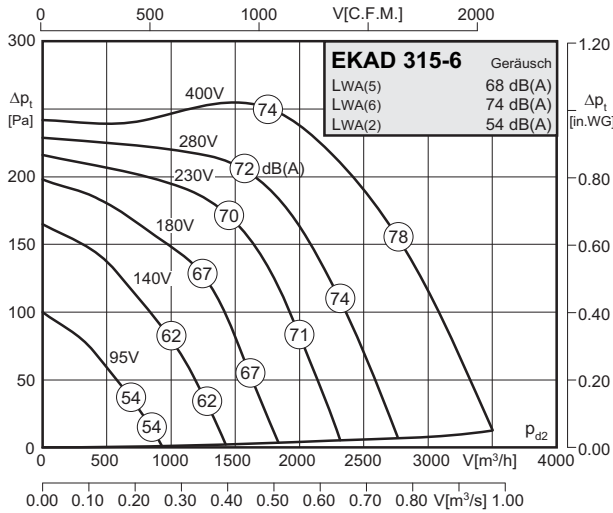

Typ / Type: <b>EKAD 315-6</b>		Art.-Nr. / Art.-No.: <b>D00-31553</b>	
U	400V (50Hz)	Δp <sub>fa min</sub>	-- Pa
P <sub>1</sub>	0,82 kW	ΔI	-- %
I <sub>N</sub>	1.5 A	I <sub>A</sub> / I <sub>N</sub>	2.1
n	740 min <sup>-1</sup>		IP54
C <sub>400V</sub>	-- μF		01.006
t <sub>R</sub>	45 °C		36 kg

### Geräusche / Sound levels:

LWA <sub>rel</sub> A-bewertet bei V=0,5*V <sub>max</sub> LWA <sub>rel</sub> A-weighted at V=0,5*V <sub>max</sub>	fM [Hz]						
	125	250	500	1K	2K	4K	8K
Gehäuse 6-polig / casing 6-pole	-10	-9	-4	-7	-9	-14	-21
Ansaugseite 6-polig / inlet side 6-pole	-17	-15	-7	-6	-6	-7	-14
Ausblasseite 6-polig / outlet side 6-pole	-22	-13	-7	-6	-5	-7	-15

### Schaltbild / Wiring diagram:

01.006

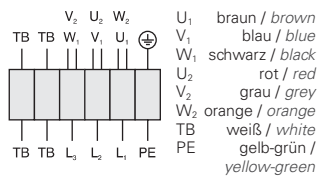

### Maße / Dimensions: (alle Maße in mm / all dimensions in mm)

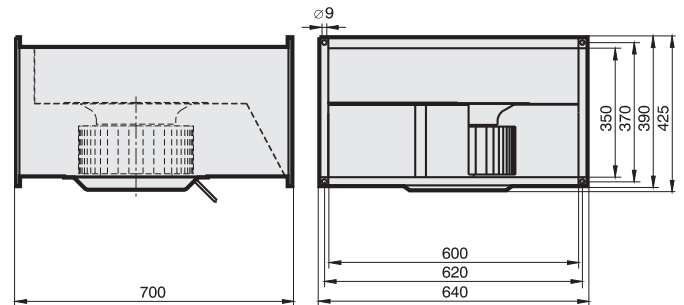

### Zubehör / Accessories:





# Kanalventilatoren (vorwärtsgekrümmt) / Duct Fans (forward curved)

## Baugröße / Size: 355



- schnelle Montage an DIN-Normflansch
- vorwärtsgekrümmtes Laufrad
- in allen Einbaulagen einsetzbar
- kompakte, raumsparende Bauart
- Isolierstoffklasse F
- extrem geringer Anlaufstrom
- Motorschutz durch Thermokontakte
- transformatorisch 100% stufenlos steuerbar
- easy installation (DIN standard flange)
- forward curved impeller
- can be installed in any position
- compact and space saving design
- insulation class F
- extremely low starting currents
- motor protection by thermal contacts
- speed is 100% infinitely variable using auto transformers

### Technische Daten / Technical Data:

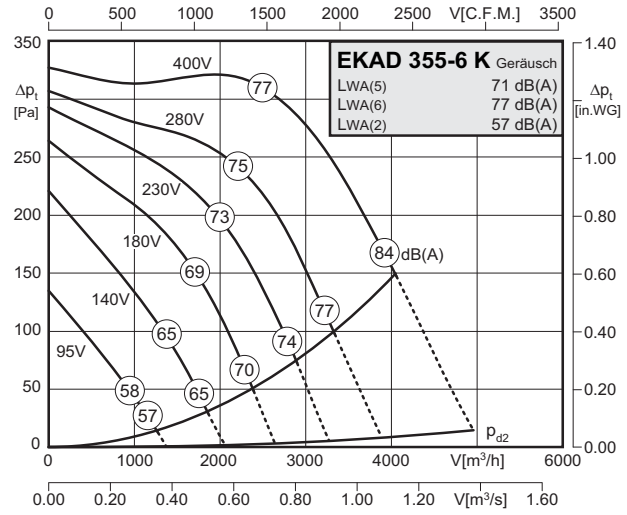
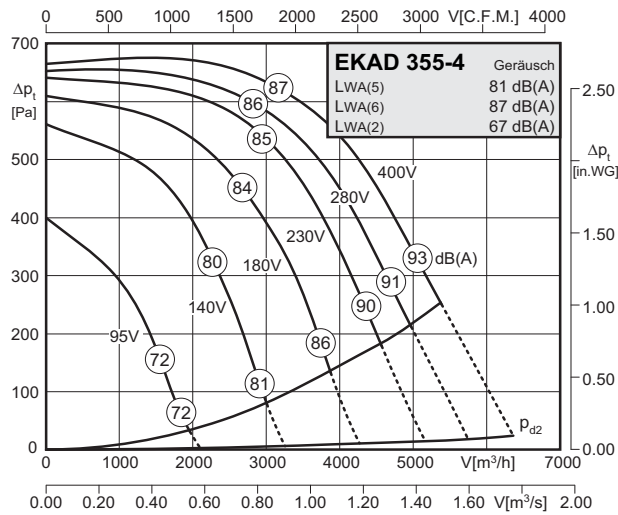

Typ / Type: <b>EKAD 355-4</b>		Art.-Nr. / Art.-No.: <b>D00-35500</b>	
U	400V (50Hz)	ΔP <sub>fa</sub> min	240 Pa
P <sub>1</sub>	3.2 kW	ΔI	12 %
I <sub>N</sub>	5.8 A	I <sub>A</sub> / I <sub>N</sub>	5.2
n	1405 min <sup>-1</sup>	⚠	IP54
C <sub>400V</sub>	- μF	✳	01.006
t <sub>R</sub>	40 °C	🔌	58 kg

Typ / Type: <b>EKAD 355-6 K</b>		Art.-Nr. / Art.-No.: <b>D00-35553</b>	
U	400V (50Hz)	ΔP <sub>fa</sub> min	140 Pa
P <sub>1</sub>	1.15 kW	ΔI	- %
I <sub>N</sub>	2.20 A	I <sub>A</sub> / I <sub>N</sub>	2.4
n	810 min <sup>-1</sup>	⚠	IP54
C <sub>400V</sub>	- μF	✳	01.006
t <sub>R</sub>	40 °C	🔌	50 kg

### Geräusche / Sound levels:

LWA <sub>rel</sub> A-bewertet bei V=0,5*V <sub>max</sub> LWA <sub>rel</sub> A-weighted at V=0,5*V <sub>max</sub>	fM [Hz]						
	125	250	500	1K	2K	4K	8K
Gehäuse 4-polig / casing 4-pole	-5	-7	-9	-7	-12	-17	-24
Ansaugseite 4-polig / inlet side 4-pole	-13	-15	-6	-5	-7	-9	-18
Ausblasseite 4-polig / outlet side 4-pole	-16	-14	-8	-5	-6	-7	-17

LWA <sub>rel</sub> A-bewertet bei V=0,5*V <sub>max</sub> LWA <sub>rel</sub> A-weighted at V=0,5*V <sub>max</sub>	fM [Hz]						
	125	250	500	1K	2K	4K	8K
Gehäuse 6-polig / casing 6-pole	-10	-9	-4	-7	-9	-14	-21
Ansaugseite 6-polig / inlet side 6-pole	-17	-15	-7	-6	-6	-7	-14
Ausblasseite 6-polig / outlet side 6-pole	-22	-13	-7	-6	-5	-7	-15

### Schaltbild / Wiring diagram:

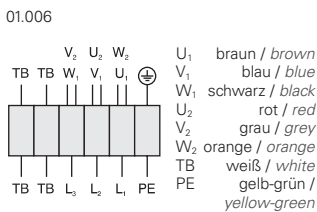

### Maße / Dimensions: (alle Maße in mm / all dimensions in mm)

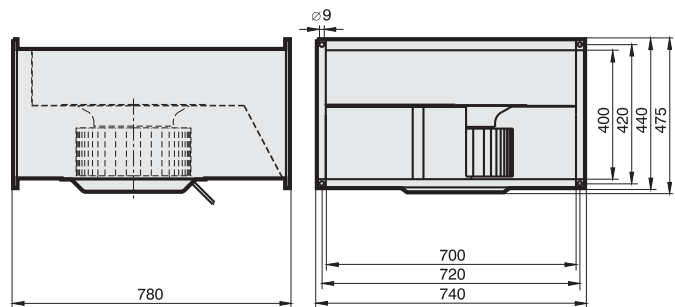

### Zubehör / Accessories:





- schnelle Montage an DIN-Normflansch
- vorwärtsgekrümmtes Laufrad
- in allen Einbaulagen einsetzbar
- kompakte, raumsparende Bauart
- Isolierstoffklasse F
- extrem geringer Anlaufstrom
- Motorschutz durch Thermokontakte
- transformatorisch 100% stufenlos steuerbar
- easy installation (DIN standard flange)
- forward curved impeller
- can be installed in any position
- compact and space saving design
- insulation class F
- extremely low starting currents
- motor protection by thermal contacts
- speed is 100% infinitely variable using auto transformers

### Technische Daten / Technical Data:

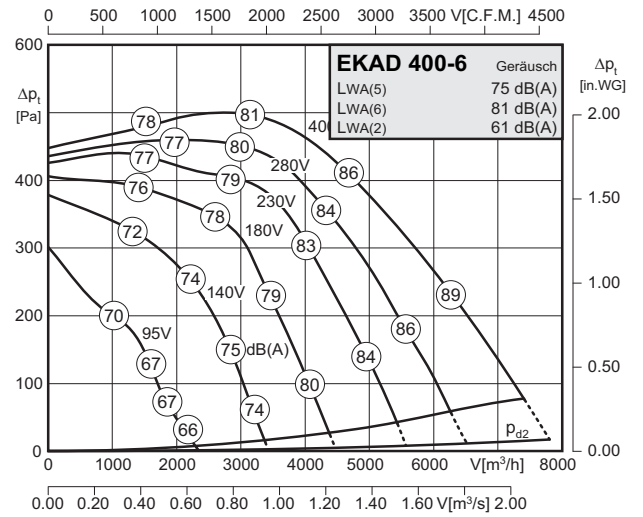
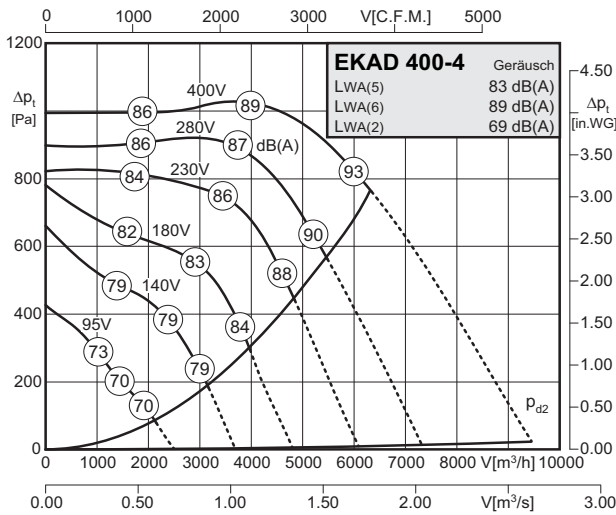

Typ / Type: <b>EKAD 400-4</b>		Art.-Nr. / Art.-No.: <b>D00-40050</b>	
U	400V (50Hz)	$\Delta p_{fa \text{ min}}$	750 Pa
P <sub>1</sub>	4,25 kW	$\Delta I$	15 %
I <sub>N</sub>	7,30 A	I <sub>A</sub> / I <sub>N</sub>	4,0
n	1345 min <sup>-1</sup>		IP54
C <sub>400v</sub>	- μF		01.006
t <sub>R</sub>	40 °C		86 kg

Typ / Type: <b>EKAD 400-6</b>		Art.-Nr. / Art.-No.: <b>D00-40051</b>	
U	400V (50Hz)	$\Delta p_{fa \text{ min}}$	50 Pa
P <sub>1</sub>	2,8 kW	$\Delta I$	10 %
I <sub>N</sub>	5,4 A	I <sub>A</sub> / I <sub>N</sub>	3,3
n	865 min <sup>-1</sup>		IP54
C <sub>400v</sub>	- μF		01.006
t <sub>R</sub>	40 °C		82 kg

### Geräusche / Sound levels:

LWA <sub>rel</sub> A-bewertet bei V=0,5*V <sub>max</sub> LWA <sub>rel</sub> A-weighted at V=0,5*V <sub>max</sub>	fM [Hz]						
	125	250	500	1K	2K	4K	8K
Gehäuse 4-polig / casing 4-pole	-5	-7	-9	-7	-12	-17	-24
Ansaugseite 4-polig / inlet side 4-pole	-13	-15	-6	-5	-7	-9	-18
Ausblasseite 4-polig / outlet side 4-pole	-16	-14	-8	-5	-6	-7	-17

LWA <sub>rel</sub> A-bewertet bei V=0,5*V <sub>max</sub> LWA <sub>rel</sub> A-weighted at V=0,5*V <sub>max</sub>	fM [Hz]						
	125	250	500	1K	2K	4K	8K
Gehäuse 6-polig / casing 6-pole	-10	-9	-4	-7	-9	-14	-21
Ansaugseite 6-polig / inlet side 6-pole	-17	-15	-7	-6	-6	-7	-14
Ausblasseite 6-polig / outlet side 6-pole	-22	-13	-7	-6	-5	-7	-15

### Schaltbild / Wiring diagram:

01.006

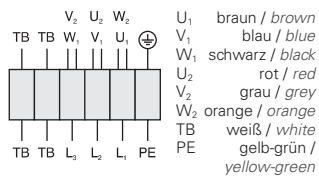

### Maße / Dimensions: (alle Maße in mm / all dimensions in mm)

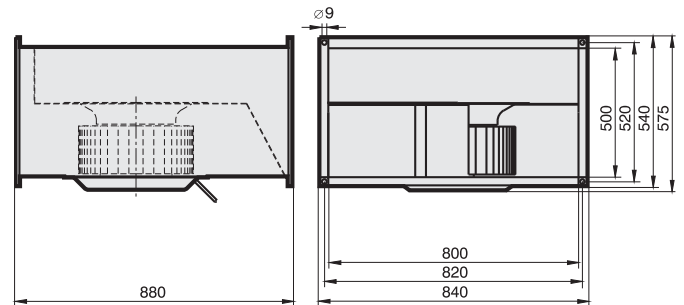

### Zubehör / Accessories:



# Kanalventilatoren (vorwärtsgekrümmt) / Duct Fans (forward curved)

## Baugröße / Size: 400



- schnelle Montage an DIN-Normflansch
- vorwärtsgekrümmtes Laufrad
- in allen Einbaulagen einsetzbar
- kompakte, raumsparende Bauart
- Isolierstoffklasse F
- extrem geringer Anlaufstrom
- Motorschutz durch Thermokontakte
- transformatorisch 100% stufenlos steuerbar
- easy installation (DIN standard flange)
- forward curved impeller
- can be installed in any position
- compact and space saving design
- insulation class F
- extremely low starting currents
- motor protection by thermal contacts
- speed is 100% infinitely variable using auto transformers

### Technische Daten / Technical Data:

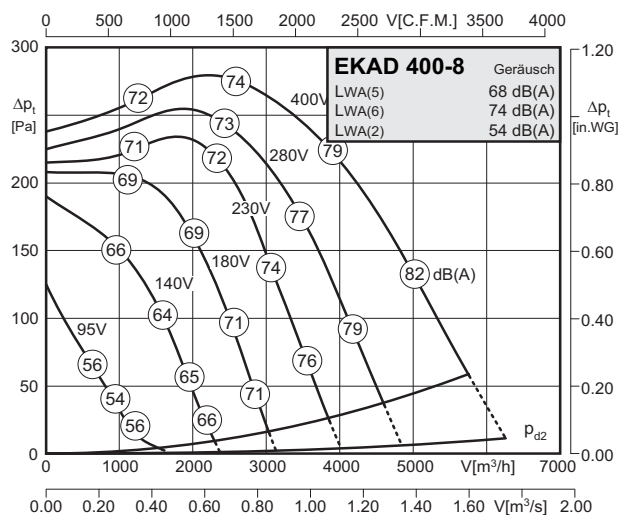

Typ / Type: <b>EKAD 400-8</b>		Art.-Nr. / Art.-No.: <b>D00-40052</b>	
U	400V (50Hz)	Δp <sub>fa</sub> min	50 Pa
P <sub>1</sub>	1.4 kW	ΔI	- %
I <sub>N</sub>	3.0 A	I <sub>A</sub> / I <sub>N</sub>	2.6
n	635 min <sup>-1</sup>		IP54
C <sub>400V</sub>	- μF		01.006
t <sub>R</sub>	40 °C		75 kg

### Geräusche / Sound levels:

LWA <sub>rel</sub> A-bewertet bei V=0,5*V <sub>max</sub> LWA <sub>rel</sub> A-weighted at V=0,5*V <sub>max</sub>	fM [Hz]						
	125	250	500	1K	2K	4K	8K
Gehäuse 6-polig / casing 6-pole	-10	-9	-4	-7	-9	-14	-21
Ansaugseite 6-polig / inlet side 6-pole	-17	-15	-7	-6	-6	-7	-14
Ausblasseite 6-polig / outlet side 6-pole	-22	-13	-7	-6	-5	-7	-15

### Schaltbild / Wiring diagram:

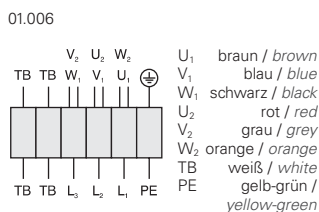

### Zubehör / Accessories:



### Maße / Dimensions: (alle Maße in mm / all dimensions in mm)

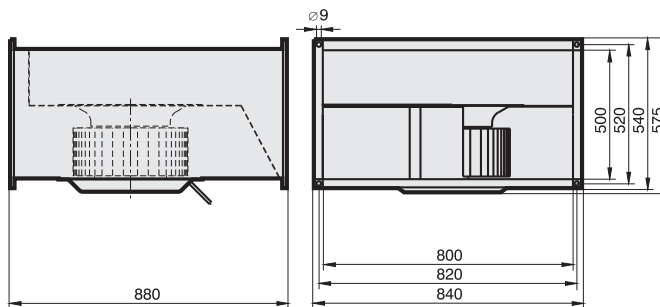



- schnelle Montage an DIN-Normflansch
- vorwärtsgekrümmtes Laufrad
- in allen Einbaulagen einsetzbar
- kompakte, raumsparende Bauart
- Isolierstoffklasse F
- extrem geringer Anlaufstrom
- Motorschutz durch Thermokontakte
- transformatorisch 100% stufenlos steuerbar
- easy installation (DIN standard flange)
- forward curved impeller
- can be installed in any position
- compact and space saving design
- insulation class F
- extremely low starting currents
- motor protection by thermal contacts
- speed is 100% infinitely variable using auto transformers

### Technische Daten / Technical Data:

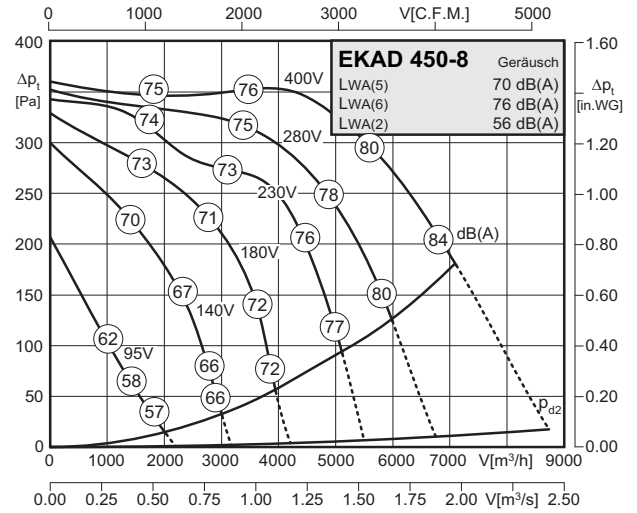
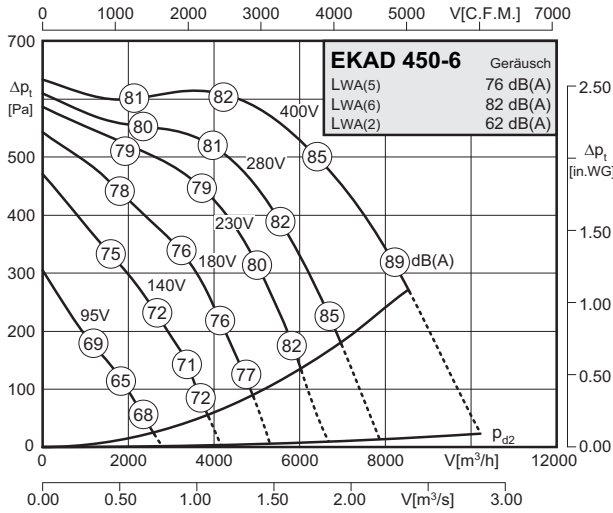

Typ / Type: <b>EKAD 450-6</b>		Art.-Nr. / Art.-No.: <b>D00-45050</b>	
U	400V (50Hz)	Δp <sub>fa</sub> min	250 Pa
P <sub>1</sub>	3,5 kW	ΔI	2 %
I <sub>N</sub>	6.90 A	I <sub>A</sub> / I <sub>N</sub>	3.2
n	845 min <sup>-1</sup>	▲	IP54
C <sub>400v</sub>	- μF	★	01.006
t <sub>R</sub>	40 °C	■	97 kg

Typ / Type: <b>EKAD 450-8</b>		Art.-Nr. / Art.-No.: <b>D00-45051</b>	
U	400V (50Hz)	Δp <sub>fa</sub> min	170 Pa
P <sub>1</sub>	2,0 kW	ΔI	5 %
I <sub>N</sub>	3.9 A	I <sub>A</sub> / I <sub>N</sub>	3.2
n	650 min <sup>-1</sup>	▲	IP54
C <sub>400v</sub>	- μF	★	01.006
t <sub>R</sub>	40 °C	■	85 kg

### Geräusche / Sound levels:

LWA <sub>rel</sub> A-bewertet bei V=0,5*V <sub>max</sub> LWA <sub>rel</sub> A-weighted at V=0,5*V <sub>max</sub>	fM [Hz]						
	125	250	500	1K	2K	4K	8K
Gehäuse 6-polig / casing 6-pole	-10	-9	-4	-7	-9	-14	-21
Ansaugseite 6-polig / inlet side 6-pole	-17	-15	-7	-6	-6	-7	-14
Ausblasseite 6-polig / outlet side 6-pole	-22	-13	-7	-6	-5	-7	-15

LWA <sub>rel</sub> A-bewertet bei V=0,5*V <sub>max</sub> LWA <sub>rel</sub> A-weighted at V=0,5*V <sub>max</sub>	fM [Hz]						
	125	250	500	1K	2K	4K	8K
Gehäuse 6-polig / casing 6-pole	-10	-9	-4	-7	-9	-14	-21
Ansaugseite 6-polig / inlet side 6-pole	-17	-15	-7	-6	-6	-7	-14
Ausblasseite 6-polig / outlet side 6-pole	-22	-13	-7	-6	-5	-7	-15

### Schaltbild / Wiring diagram:

01.006

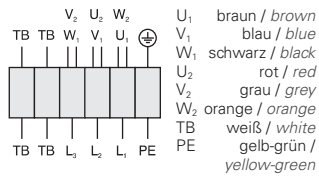

### Zubehör / Accessories:



### Maße / Dimensions: (alle Maße in mm / all dimensions in mm)

